



JNQ00282-F-001

Carnival Flower Cordyline Cactus: This booklet and chapter includes the foundation papers, template layout sheets, and instructions needed to complete the cutting and piecing for Group F:

- **Group F: Units F1, F2, & Applique Circle Sheets**

General Block Information: The F-Block units were designed to teach you to paperpiece staggered seams, which is used for many Quiltworx designs. The staggered seams don't match when the blocks are joined to eliminate bulk when sewing two adjacent units together with repeating spikes. The Cordyline Cactus block matches with opposing seams at the tip of the first point. However, all the remaining seams are staggered anywhere between 1/4" to 1/2". On a scale of 1 to 10, one being simple and 10 very difficult, I would rate this block at about 3. The paper piecing process is simple. When you begin to assemble the block, just remember that the seams don't match, except at the top point. The cutting process for the section templates include Template Layout Sheets for the background sections and then multiple layout sheets for each spike sections to allow for multiple colors in the placement of each spike.

Newsprint NP 926, TP 752, and TP 726: The newsprint in your instructions package includes the Foundation Papers and Template Layout Sheets (TLS) required to complete the cutting and piecing instructions for Units F1 & F2. We have also included Applique Grid Layouts for those of you who choose to work with the digitized embroidery designs by Vanessa Fromm, from Fabric Confetti.

Reference Page 3 of the Introduction Booklet under ***Foundation Papers and Templates** for instructions on how to cut out the Foundation Papers, and Template Layout Sheets in this booklet.

After the Foundation Papers and Template Layout Sheets are cut out, the papers labeled Unit F1, & F2 are placed into their associated Bag #s listed below. The Template Layout Sheets are stacked in numerical order (TLS) 1-8, then placed into a temporary bag assigned to the Group F Templates. After the templates are placed with their assigned fabrics and the template cutting is completed for each fabric, the templates and fabrics are then placed with the foundation papers into their assigned Bags.

Cordyline Cactus Group-F

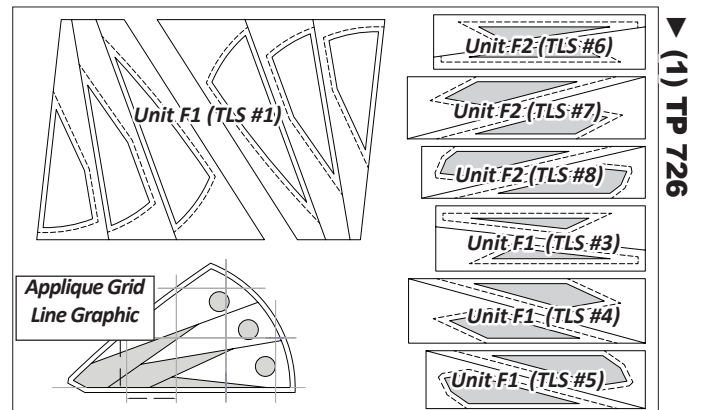
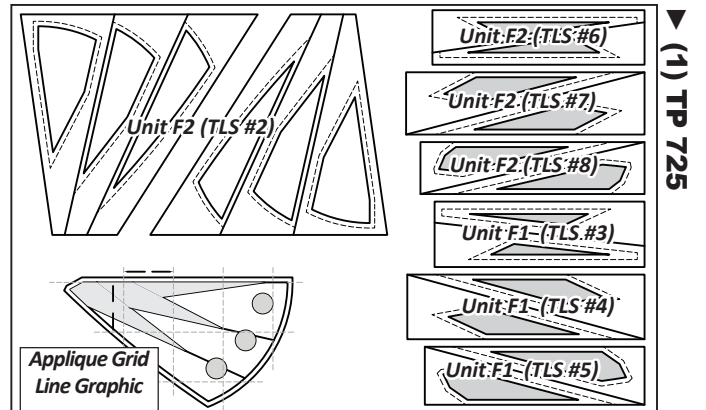
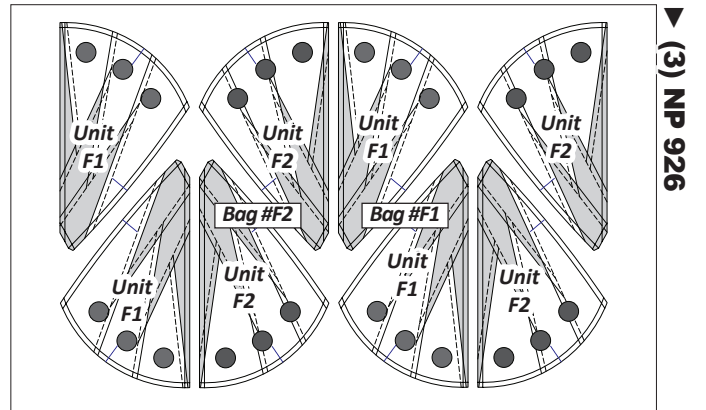

Ziploc Bags: (4) large Ziploc bags are needed to keep your fabrics, templates, and papers organized. Label as follows:

- **Bag #F1:** (12 Unit F1 Foundation Papers)
- **Bag #F2:** (12) Unit F2 Foundation Papers
- **Group F, Temp Bag:** (Template Layout Sheets 1-8).
- **Group F, Applique Bag:** Circle Sheets (JNQ282-F-001-AP).



Carnival Crown, Group-G

JNQ00282-G-001

Carnival Crown: This booklet and chapter includes the foundation papers, template layout sheets, and instructions needed to complete the cutting and piecing for Group G:

- **Group G: Units G1 & Unit G2**

General Block Information: The G-Block units were designed to teach traditional curved piecing, traditional S-curve piecing, curved paper piecing with veins, and then how to transform your foundation papers into T-Templates. We have also added the dots for the applique. Template Layout Sheets are used to cut all the template pieces.

Newsprint NP 939, TP 747, and TP 748: The newsprint in your instructions package includes the Foundation Papers and Template Layout Sheets (TLS) required to complete the cutting and piecing instructions for both Units G1 and G2.

Reference Page 3 of the Introduction Booklet under ***Foundation Papers and Templates** for instructions on how to cut out the Foundation Papers, and Template Layout Sheets in this booklet.

After the Foundation Papers and Template Layout Sheets are cut out, the papers labeled Unit G1, & G2 are placed into their associated Bag #s listed below. The Template Layout Sheets are stacked in numerical order (TLS) 1-4, then placed into a temporary bag assigned to the Group G Templates. After the templates are placed with their assigned fabrics and the template cutting is completed for each fabric, the templates and fabrics are then placed with the foundation papers into their assigned Bags.

Ziploc Bags: (3) large Ziploc bags are needed to keep your fabrics, templates, and papers organized. Label as follows:

- **Bag #G1: (12) Unit G1** Foundation Papers
- **Bag #G2: (12) Unit G2** Foundation Papers
- **Group G, Temp Bag:** (Template Layout Sheets 1-4).

Color Options: We have provided two color options for Units G1 & G2. The **Standard Option** requires no paper piecing. The foundation papers are transformed into T-Templates, which removes the curved veins along the top edge of each unit. The cutting instructions are designed so all (12) unit groups are made with the same fabrics. To get some variation of color using the Standard Option, you can change your background fabrics from block to block by using the Unlock setting on Quiltster.

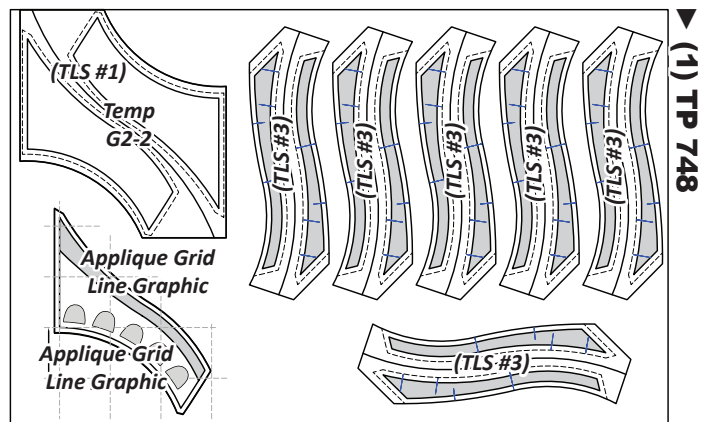
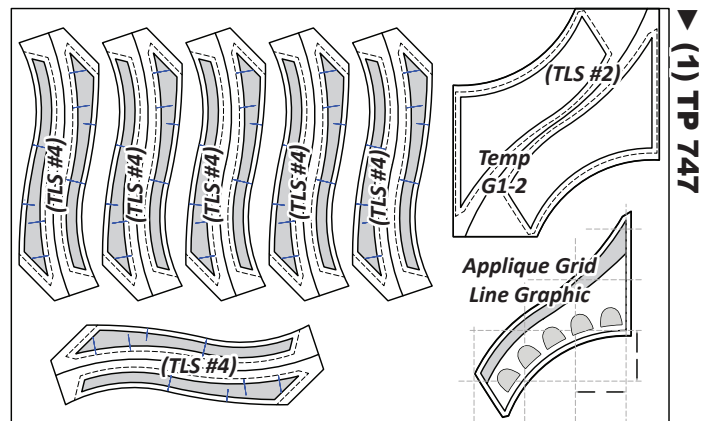
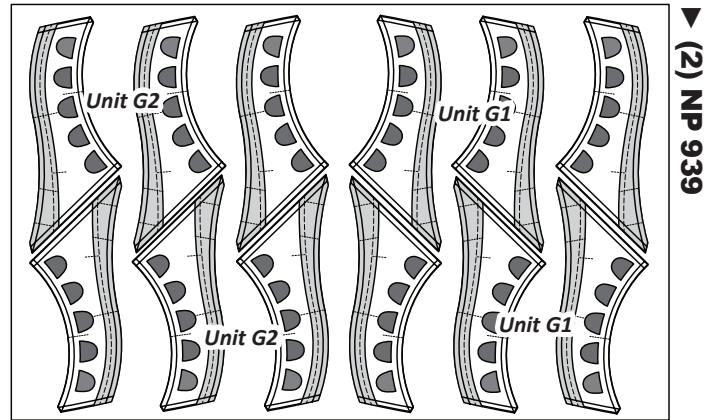

The **Alternative 1 Color Option** is designed so all (12) unit groups are made with the same fabrics. It is easy to get some variation of color if you change your fabrics from block to block. This can be done by using the Unlock setting on Quiltster. None of the quilts on the cover were designed with the **Alternative 1 Color Option**. This option was not available until after all the cover samples were designed.

Yardage Chart Information: The yardage information presented in the Fabric Chart is presented for the One Color Group, where all (12) blocks look the same. If you are working with (2) or more color groups, the total yardage might change depending on how the colors are used. If you are working with (3) colors, four units are