

▶ (2) NP 781

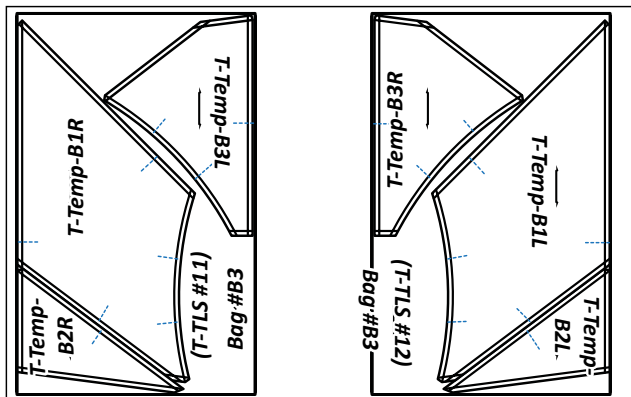

▶ (1) TP 573

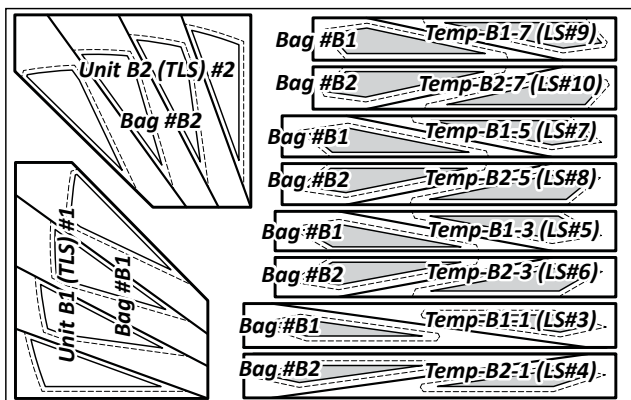

▶ (1) TP 574

▶ **Fabric Information:**

The *Unit Chart* that follows includes yardage, fabric numbers, and a reference to which fabrics go with the Templates and (TLS) to complete **Units B1 & B2**. The color layout, shown below, gives a visual reference to where the fabrics are located on each unit.

<b>Units B1 &amp; B2: Make (8) ea. Left &amp; Right Units</b>		
GROUP-B FABRIC #	YDS INCH	ASSIGNED COLORS
<u>Fabric B1:a</u> Unit B1 & B2, (TLS) #1 & #2	<u>5/8 yd</u> or (21")	Fabric Swatch
<u>Fabric B1:b</u> Unit B1 & B2, (TLS) #1 & #2	<u>5/8 yd</u> or (21")	Fabric Swatch
<u>Fabric B2:a</u> Unit B1 & B2, (TLS) #3 & #4	<u>1/4 yd</u> or (5")	Fabric Swatch
<u>Fabric B2:b</u> Unit B1 & B2, (TLS) #3 & #4	<u>1/4 yd</u> or (5")	Fabric Swatch
<u>Fabric B3:a</u> Unit B1 & B2, (TLS) #5 & #6	<u>1/4 yd</u> or (5")	Fabric Swatch
<u>Fabric B3:b</u> Unit B1 & B2, (TLS) #5 & #6	<u>1/4 yd</u> or (5")	Fabric Swatch
<u>Fabric B4:a</u> Unit B1 & B2, (TLS) #7 & #8	<u>1/4 yd</u> or (5")	Fabric Swatch
<u>Fabric B4:b</u> Unit B1 & B2, (TLS) #7 & #8	<u>1/4 yd</u> or (5")	Fabric Swatch
<u>Fabric B5:a</u> Unit B1 & B2, (TLS) #9 & #10	<u>1/4 yd</u> or (5")	Fabric Swatch
<u>Fabric B5:b</u> Unit B1 & B2, (TLS) #9 & #10	<u>1/4 yd</u> or (5")	Fabric Swatch
<u>Fabric B6</u> T-Temp B1R-B3R & B1L- B3L	<u>1-1/2 yds</u> or (52")	Fabric Swatch

▶ **Fabric Color Layout**

**NOTE - Backside Graphic:** The color layout shown matches the printed side of the paper, and the backside of the quilt.

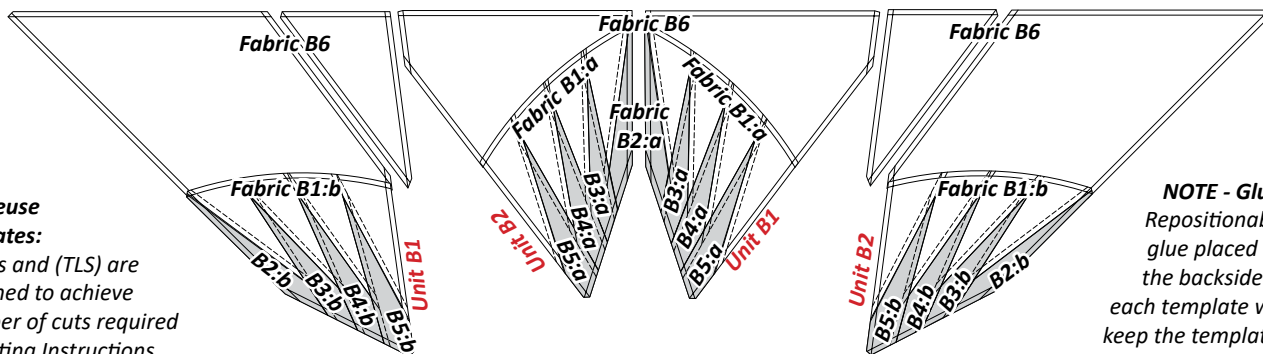

**NOTE - Reuse of Templates:** Templates and (TLS) are repositioned to achieve the number of cuts required in the cutting Instructions. Please read carefully to ensure the correct # of pieces are stacked beneath each Template before cutting.

**NOTE - Glue:** Repositionable glue placed on the backside of each template will keep the templates from moving in the cutting process.

## GROUP B ASSEMBLY

**Removing Paper:** It is recommended that you only remove the foundation paper from each Unit just prior to joining it to another block or block group. Some of the elements do not require you to remove the paper until you are ready to assemble the whole quilt project, while other elements are joined at this time to complete the block group that you are working on. It is important that you read forward before sewing any of the block groups together.

**Registration Lines:** If you did not sew your *Registration Lines* you need to complete them before removing the paper.

### ► Finishing the Blocks

**Step 1:** Refer to the Group B Layout, below, when joining sections. **Temp B1L is joined with Unit B2, Temp B3L is joined with Unit B1, Temp B3R is joined with Unit B2, and Temp B1R is joined with Unit B1.** Note that the templates and units have been designed with Smart Corners at both ends. The Smart Corners will align perfectly as long as you cut them correctly when trimming the papers.

**Curved Piecing Tips:** Match and pin the TRP lines. A glue pen is used to secure the end points and raw edges together.

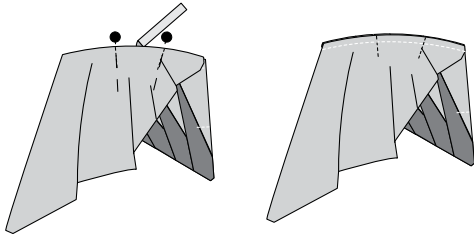

**Step 2:** Complete the sewing on each block group, then press the seams toward Template B1L, B3L, B3R and B1R. To avoid Y-seams in the assembly process, the remaining units are **NOT** joined at this time. The pieces are set aside until all the piecing is completed for the remaining groups used to create your quilt project.

**Group B Layout:** The unit references shown below match the front side of the border.

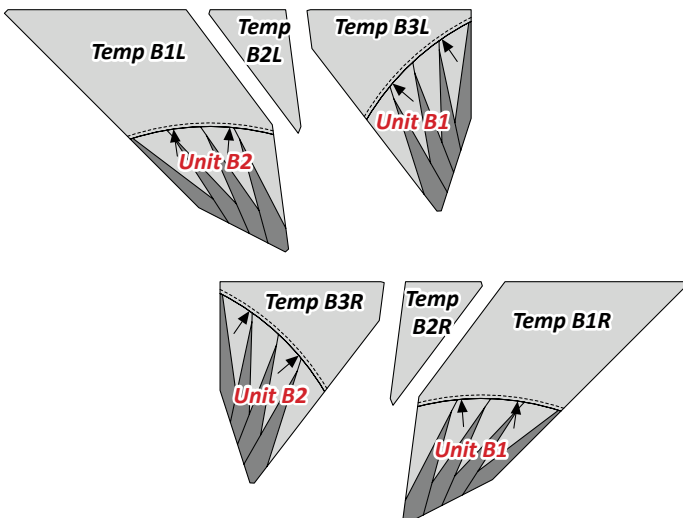

## GROUP C: RICRAC BORDER INSTRUCTIONS

**Ziploc Storage Bags:** You will need (3) bags to complete the organization for these instructions. Label the bags as follows.

- Bag #1: (4) Unit CR, (TLS #1), (TLS #4)
- Bag #2: (4) Unit CL, (TLS #2), (TLS #3)
- Bag #3: T-Template Layout Sheet #5

### ► Preparing the Foundation Papers:

Cut out the Foundation Papers and cutting templates included on [NP 728 & 729] then [TP 548]. Reference the newsprint graphics for the location of each Unit, Template, and Template Layout Sheet along with the associated Bag #s. *\*Refer back to General Information for Foundation Papers and Templates for additional instructions on how to prepare your foundation papers and templates.*

**NOTE - Reusing Templates:** Templates and (TLS) are repositioned on the cut strips to achieve the number of cuts required in the cutting Instructions. Please read carefully to ensure the correct # of pieces are stacked beneath each Template before cutting.

