

**Cutting and Stacking Techniques:** Efficiency has also been incorporated into our cutting techniques through the use of paper piecing templates and Template Layout Sheets. If these concepts are new to you, you will find them to be one of the most satisfying parts of our patterns. Template Layout Sheets were designed to teach organization skills, save hours of cutting time, and cut down on wasted fabric. We also include graphics showing how to stack and prepare fabric pieces before cutting and before paper piecing, using the Templates as a guide for staying organized. Again, our goal is to save you hours of sorting and sewing, by establishing a "procedural process" that keeps you focused on one step at a time and also minimizes mistakes!

**Cut Out Technique:** This pattern teaches a technique we use in several of our quilts that requires you to piece your unit, then go back and cut part of it away to create a 3-dimensional overlap of units.

**Design Elements:** There are (3) design elements used to create the layout in this pattern. They are referred to as Unit A, Unit B, and Unit C.

## GENERAL INFORMATION FOR FOUNDATION PAPERS AND TEMPLATES

**Ziploc Bags:** You will need (4) large Ziploc bags to keep your pieces organized. Label the Bags according to the information below. You will sort the Foundation Papers, Templates, Cut Out Templates, and Template Layout Sheets according to the information on the newsprint graphics shown on the following two pages.

- Bag #1: Unit A (30) Foundation Papers and (3) Unit A Background and Accent Templates Layout Sheets.
- Bag #2: Unit B (80) Foundation Papers and (8) Unit B Background and Accent Templates Layout Sheets
- Bag #3: Unit C (24) Foundation Papers and (3) Unit C Background and Accent Templates Layout Sheets.
- Bag #4: Background T-Templates and CT-Templates.

**NOTE - Extra Template Layout Sheets and Units:** To optimize the layout for these papers, you will have some extra foundation papers and layout sheets. You can discard the excess in your pattern or save them in case you make a mistake.

**Preparing Newsprint (NP) with Foundation Papers:** The Foundation Papers are used as your piecing guides and are cut out by trimming the excess paper away, *approximately 1/8"* beyond the outside cutting line. Once the papers are cut, the papers are clipped together and placed into the corresponding bags as shown in the newsprint graphics on Page 2.

**Hatching:** Hatching has been added to the foundation papers and templates. The following information about the hatching will help you throughout the pattern.

1. The shaded sections (referred to as hatching) on the foundation papers and Template Layout Sheets correspond with each other. *The hatched sections go with Fabrics B1 to B10.*
2. The unhatched sections go with Fabrics A1 to A10.
3. Hatching does not denote the use of light, medium, or dark fabric. Your background fabrics may be light, medium, or dark. Your accent fabrics may also be light, medium, or dark.
4. Sec. #s and TEMP #s assigned to the background sections and accent sections on each foundation unit are also assigned to the corresponding templates and Template Layout Sheets.

**Preparing Template Newsprint (TP):** The TP newsprint

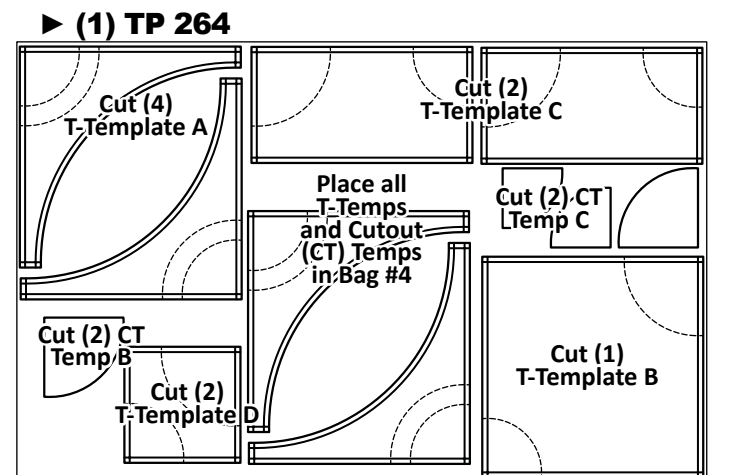
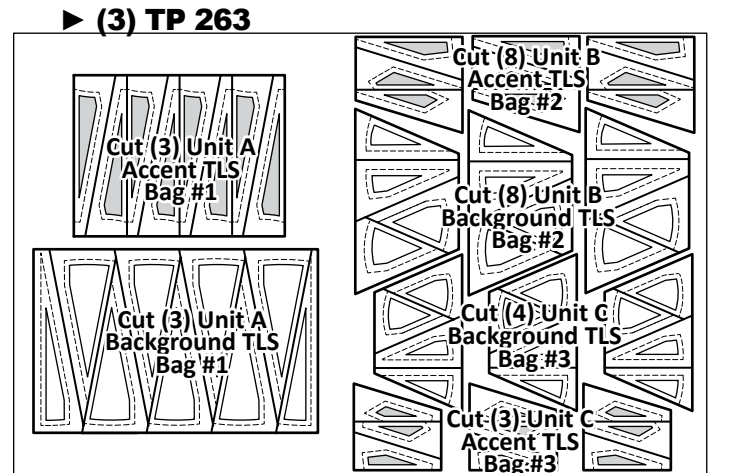
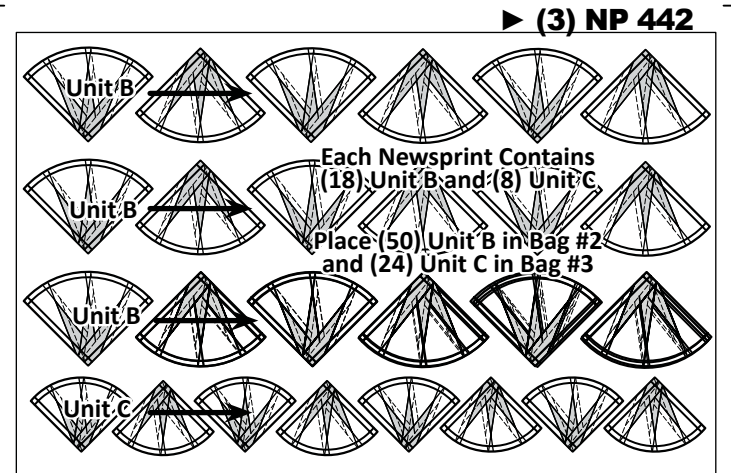
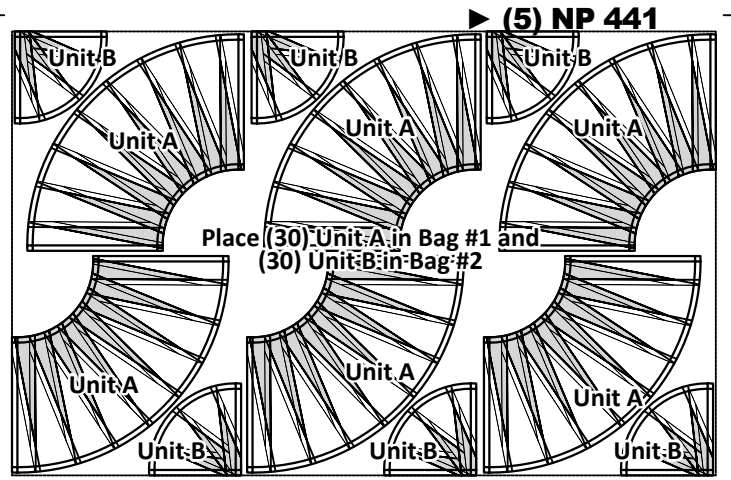

includes Traditional Templates (T-Templates), Template Layout Sheets (TLS), and Cutout Templates (CT Templates). T-Templates are used to cut pieces to the exact size needed to complete the quilt. Template Layout Sheets are cutting templates consisting of several paper piecing templates grouped into one large, pre-cut cutting template. The layout for the templates is designed to utilize grain line, save fabric and speed up the cutting process. Template Layout Sheets are then used to cut out the fabric pieces. Each layout sheet is placed onto a stack of fabric before it is cut apart. A rotary cutter slices through the paper and fabric at the same time, allowing several layers of fabric to be cut at once. A Cutout Template is used after the paper piecing is completed to cut away a portion of a foundation paper making a place to sew a new piece in its place.

Template Layout Sheets and T-Templates are cut out on the **dark solid line** that forms a box around each group. Do not cut on any of the interior Cut Lines on the Template Layout Sheets at this time.

After the cutting is completed, the templates and Template Layout Sheets are sorted, then placed into the assigned bags as noted in the newsprint graphics shown on Pages 2 and 3.

## GENERAL FABRIC INFORMATION

**Fabric Width:** The yardage amounts and cutting instructions were calculated to use 42" wide fabrics. If the fabrics are not 42" wide, you might want to recalculate the yardage before you begin cutting.

**Cutting Errors:** If cutting mistakes are made, when cutting your strip sets you will probably need to insert a new fabric color to replace what was improperly cut. If additional supplies are needed to correct an error, please contact [Quiltworx.com](http://Quiltworx.com) and we will try to help you get what you need. You will be liable to cover shipping.

**Follow Instructions:** You may find yourself confused as you begin, but let me assure you this process works. Read through the instructions, and study the graphics before you start. Follow the instructions step by step. Once you complete the first Foundation Sheet, it will all make sense and you will be hooked.

## SELECTING AND CUTTING FABRICS

**Selecting your Fabrics:** Selecting your fabrics can be done by:

- Purchasing a pre-made kit (your yardage should follow the cover quilt yardage listed on the back of the pattern or in the table to the right).
- You can select your own fabrics using the same color concept as the cover, simply choosing

your own colors in the same yardage amounts as recommended on the back of the pattern or below. Just paste your own fabric choices into each box.

- You can use Quiltster! In this case, you can use a pre-loaded color template to play with real fabric swatches and audition color concepts and a wide range of fabrics to create your very own, unique version of Raindrops. Your yardage will calculate out as shown below, but you will be able to see your quilt before you finalize your fabric choices.

Once you decide on your fabrics, press them and begin the cutting process. You will cut all of the accent fabrics at the same time, then sort the pieces into the proper bags. Then, all of the background fabrics and sort the pieces into the proper bags.

**Cutting Errors:** If cutting mistakes are made during the cutting steps for each bag, you will probably need to purchase some additional fabrics to complete your project, so follow directions carefully.

## CUTTING INSTRUCTIONS

**Cutting Your Fabric:** Read the information printed on each Template Layout Sheet before you begin cutting your fabrics. **Note the following:**

<b>Full Quilt Yardage *See Note on Back Page Before Cutting</b>					
<b>ACCENT FABRICS (UNIT A, B, AND C BACKGROUNDS)</b>			<b>BACKGROUND FABRICS (UNIT A, B, AND C ACCENTS, AND T-TEMPS)</b>		
<b>FABRIC #</b>	<b>YARDAGE INCH</b>	<b>ASSIGNED COLOR</b>	<b>FABRIC #</b>	<b>YARDAGE INCH</b>	<b>ASSIGNED COLOR</b>
<u>Fabric A1</u> ACCENT 1	<u>5/8 yd</u> or (19")	FABRIC SWATCH	<u>Fabric B1</u> BACKGROUND 1	<u>7/8 yd</u> or (28-3/4")	FABRIC SWATCH
<u>Fabric A2</u> ACCENT 2	<u>5/8 yd</u> or (19")	FABRIC SWATCH	<u>Fabric B2</u> BACKGROUND 2	<u>7/8 yd</u> or (28-3/4")	FABRIC SWATCH
<u>Fabric A3</u> ACCENT 3	<u>5/8 yd</u> or (19")	FABRIC SWATCH	<u>Fabric B3</u> BACKGROUND 3	<u>7/8 yd</u> or (28-3/4")	FABRIC SWATCH
<u>Fabric A4</u> ACCENT 4	<u>5/8 yd</u> or (19")	FABRIC SWATCH	<u>Fabric B4</u> BACKGROUND 4	<u>7/8 yd</u> or (28-3/4")	FABRIC SWATCH
<u>Fabric A5</u> ACCENT 5	<u>5/8 yd</u> or (19")	FABRIC SWATCH	<u>Fabric B5</u> BACKGROUND 5	<u>7/8 yd</u> or (28-3/4")	FABRIC SWATCH
<u>Fabric A6</u> ACCENT 6	<u>5/8 yd</u> or (19")	FABRIC SWATCH	<u>Fabric B6</u> BACKGROUND 6	<u>7/8 yd</u> or (28-3/4")	FABRIC SWATCH
<u>Fabric A7</u> ACCENT 7	<u>5/8 yd</u> or (19")	FABRIC SWATCH	<u>Fabric B7</u> BACKGROUND 7	<u>7/8 yd</u> or (28-3/4")	FABRIC SWATCH
<u>Fabric A8</u> ACCENT 8	<u>5/8 yd</u> or (19")	FABRIC SWATCH	<u>Fabric B8</u> BACKGROUND 8	<u>7/8 yd</u> or (28-3/4")	FABRIC SWATCH
<u>Fabric A9</u> ACCENT 9	<u>5/8 yd</u> or (19")	FABRIC SWATCH	<u>Fabric B9</u> BACKGROUND 9	<u>7/8 yd</u> or (28-3/4")	FABRIC SWATCH
<u>Fabric A10</u> ACCENT 10	<u>5/8 yd</u> or (19")	FABRIC SWATCH	<u>Fabric B10</u> BKG RND 10	<u>7/8 yd</u> or (28-3/4")	FABRIC SWATCH

# Raindrops

**Size: 70" by 80"**

JNQ46P  
NP 441: (5) Sheets  
NP 442: (3) Sheets  
TP 263: (3) Sheets  
TP 264: (1) Sheet

## YARDAGE INFORMATION

Full Quilt Yardage - Light Background Only					
ACCENT FABRICS (UNITS A, B, AND C BACKGROUNDS)			BACKGROUND FABRICS (UNITS A, B, AND C ACCENTS AND T-TEMPS)		
FABRIC #	YARDS (INCHES)	ASSIGNED COLOR	FABRIC #	YARDS (INCHES)	ASSIGNED COLOR
Fabric A1 ACCENT 1	5/8 yd or (19")	Tonga-B4021 Flame	Fabric B1 BACKGROUND 1	7/8 yd or (28-3/4")	Tonga-B4020 Pearl
Fabric A2 ACCENT 2	5/8 yd or (19")	Tonga-B4386 Rust	Fabric B2 BACKGROUND 2	7/8 yd or (28-3/4")	Tonga-B4010 Froth
Fabric A3 ACCENT 3	5/8 yd or (19")	Tonga-B4442 Emerald	Fabric B3 BACKGROUND 3	7/8 yd or (28-3/4")	Tonga-B4001 Arctic
Fabric A4 ACCENT 4	5/8 yd or (19")	Tonga-B4001 Mermaid	Fabric B4 BACKGROUND 4	7/8 yd or (28-3/4")	Tonga-B4012 Buff
Fabric A5 ACCENT 5	5/8 yd or (19")	Tonga-B4012 Turquoise	Fabric B5 BACKGROUND 5	7/8 yd or (28-3/4")	Tonga-B4015 Ivory
Fabric A6 ACCENT 6	5/8 yd or (19")	Tonga-B4613 Teal	Fabric B6 BACKGROUND 6	7/8 yd or (28-3/4")	Tonga-B4021 Celery
Fabric A7 ACCENT 7	5/8 yd or (19")	Tonga-B4362 Cosmic	Fabric B7 BACKGROUND 7	7/8 yd or (28-3/4")	Tonga-B1115 Cream
Fabric A8 ACCENT 8	5/8 yd or (19")	Tonga-B4617 Storm	Fabric B8 BACKGROUND 8	7/8 yd or (28-3/4")	Tonga-B4012 Winter
Fabric A9 ACCENT 9	5/8 yd or (19")	Tonga-B2594 Moss	Fabric B9 BACKGROUND 9	7/8 yd or (28-3/4")	Tonga-B4007 Ice
Fabric A10 ACCENT 10	5/8 yd or (19")	Tonga-B4004 Emerald	Fabric B10 BACKGROUND 10	7/8 yd or (28-3/4")	Tonga-B4001 Whisper

Backing = 5 Yards, Binding = 3/4 Yd, Batting = 2-1/2 Yards 90" Hobbs 80/20

**NOTE - Cover Quilt with Dark Backgrounds:** The Coversheet shows a second sample that is smaller with dark backgrounds instead of light from the Wildflowers Collection by Judy and Judel Niemeyer and Timeless Treasures. This pattern uses (5) fabrics for B1 to B10, using each twice (Total bkgnd Yds = 1 3/4 per fabric). A kitting handout for the dark version is on the website and can be found by scanning the QR Code below or referencing Page 10 for a quick list of which fabrics are considered A1 to A10 and B1 to B10!

TIMELESS  
TREASURES

► Quiltster Compatible



Quiltworx.com has collaborated with a new company called Quiltster to bring you a fabric auditioning mobile application for our designs. A layout for **Raindrops** is included so you can color it with your own fabric swatches to preview your quilt before you make it! To learn more, visit Quiltster.com!

**NOTE - IMPORTANT NOTE!** Some quilters have been confused by the reference to Accent and Background fabrics. While looking at the cover quilt, the Backgrounds are the main background fabrics to the quilt, and the Accents, are the colors that pop. The spikes are made the same color as the background Templates. However, the newsprint papers have the Unit A, B, and C papers labeled with the Spikes as the Accent of the block, while the larger sections of the block are named background. While both references are technically true, retrospect tells us that Units A, B, and C should have been labeled with TLS #A1 and A2, TLS B1, and B2, etc., Instead of Accent and Background to reduce confusion. Pay special attention to which Template sheets in the pattern go to which fabrics, and don't confuse the words Accent and Background!

Visit us on:



© Copyright: November 2005

Pattern: Raindrops

All rights reserved. No part of this pattern can be reproduced in any form for any commercial purpose without the expressed written permission of Judy Niemeyer Quilting. The written instructions, foundation papers, graphics, and photographs for this pattern were designed as a package for the purpose of retail sales and as a result, fall under the protection of the federal copyright laws of the United States of America. Extra materials may be obtained from local quilt shops or directly from Judy Niemeyer Quilting aka Quiltworx.com.

Quiltworx.com  
Judy Niemeyer Quilting

E-mail: info@quiltworx.com • Web: www.quiltworx.com



Print Date: 04-20-20