

Step 3: Position (1) each of the *Unit BL and Unit BR Background Template Layout Sheets* from Bags #2AL and #2AR onto each Strip Group.

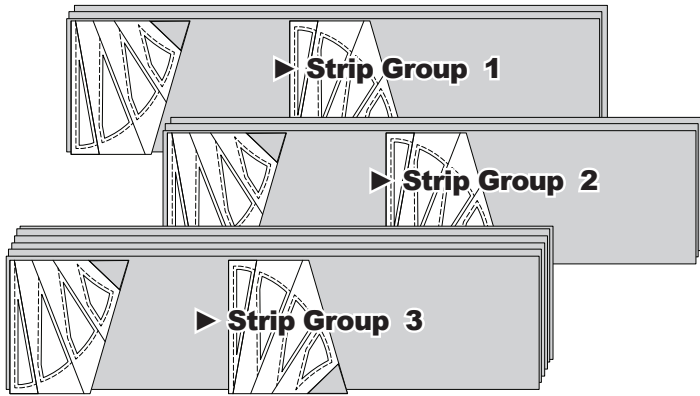

Step 4: Four stacks are cut from each strip group, (2) Left & (2) Right. Set aside the remaining fabric for T-Template A & Unit C. Paper clips are used to keep the fabric and template pieces together.

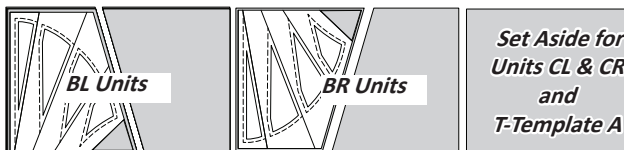

Step 5: To complete the cutting stack and cut the (6) pieces with each layout sheet, slicing through the paper on each cut line to separate the individual sections. Paper clips are used to keep the fabric and template pieces together.

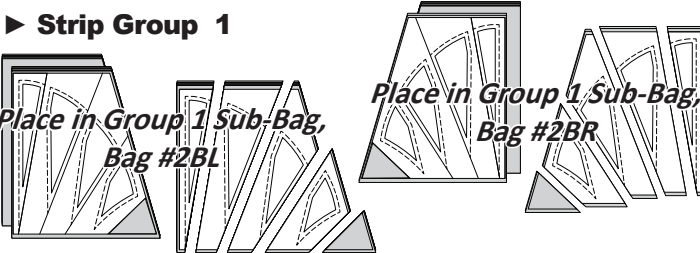

Step 6: Complete the cutting for the remaining Strip Sets and place into the appropriate bags.

- Strip Group 2 (Place BL Templates in Group 2 Sub-Bag, Bag #2BL and the BR Templates into Group 2 Sub-Bag, Bag #2BR)
- Strip Group 3 (Place BL Templates in Group 3 Sub-Bag, Bag #2BL and the BR Templates into Group 3 Sub-Bag, Bag #2BR)

► Curved Sashing, Fabric A16 (Optional Color)

NOTE - Curved Sashing: The cover quilt uses the same fabric for the curved sashing as the accent borders to conserve yardage (See Step 2 on Page 18). Follow those instructions to cut the Curved Sashing now if you are using the cover quilt color layout. To use a different fabric, you'll need extra yardage and the following cutting instructions instead.

Cut (3) 9" by 42" strips from Optional Fabric A16. Then, 1-1/4" strips are cut on the bias. Use a 45 degree angle on your ruler to get started. One 9" strip yields (18) pieces. You need a total of (54) pieces. Place (24) pieces in each Bag #2BL & #2BR. Place (3) pieces in each Bag #3CL & #3CR.

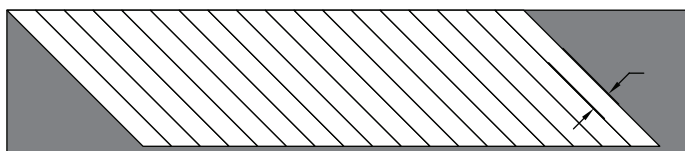

► Sorting Strip Group 1: Paired Strips 1-6

Step 7: The following pieces for each Strip Group, should be sorted and placed together in Sub-Bags if you have followed the prior instructions properly. Note the # of papers below to put in each Sub-bag.

BAG #2BL SUB-BAG GROUP 1

- Unit BL Strip Group 1: Accent Strips 1-6
- Unit BL, (TLS) Group 1: Background 1-6
- Unit BL, (6) Foundation Papers

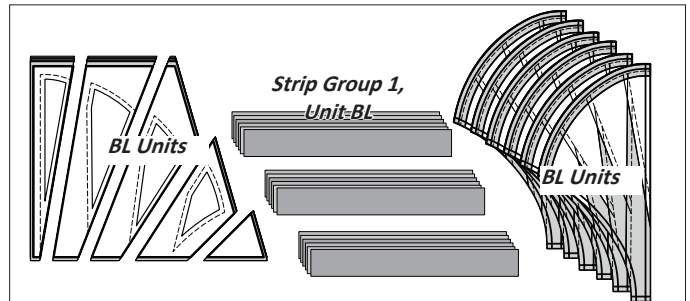

BAG #2BR SUB-GROUP 1

- Unit BR Strip Group 1: Accent Strips 1-6
- Unit BR, (TLS) Group 1: Background 1-6
- Unit BR, (6) Foundation Papers

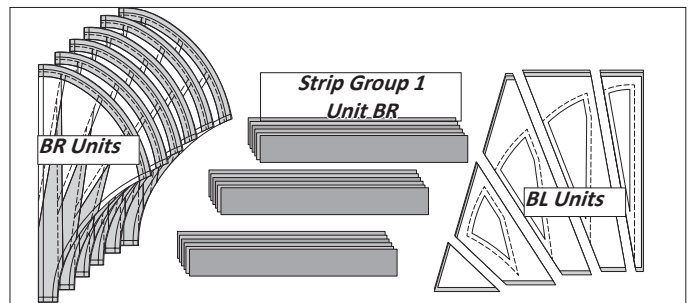

Step 8: Repeat the sorting order for *Strip Group 2* and *Strip Group 3* listed below. When you are done sorting you should have (3) Group Sets in each Bag #2BR and #2BL.

► Strip Group 2: Paired Strips 7-12

BAG #2BL SUB-BAG GROUP 2

- Unit BL Strip Group 2: Accent Strips 7-12
- Unit BL, (TLS) Group 2: Background 7-12
- Unit BL, (6) Foundation Papers

BAG #2BR SUB-BAG GROUP 2

- Unit BR Strip Group 2: Accent Strips 7-12
- Unit BR, (TLS) Group 2: Background 7-12
- Unit BR, (6) Foundation Papers

► Strip Group 3: Paired Strips 13-24

BAG #2BL SUB-BAG GROUP 3

- Unit BL Strip Group 3: Accent Strips 13-24
- Unit BL, (TLS) Group 3: Background 13-24
- Unit BL, (12) Foundation Papers

BAG #2BR SUB-BAG GROUP 3

- Unit BR Strip Group 3: Accent Strips 13-24
- Unit BR, (TLS) Group 3: Background 13-24
- Unit BL, (12) Foundation Papers