

CENTER STAR: GROUP A: BAG #1 CUTTING INSTRUCTIONS

► Foundation Papers and Templates:

Step 1: Cut out (8) Unit A Foundation Papers, along with Templates A-1 through A-13. See the newsprint graphics in the column to the right for information on how to organize your units and templates into bags. *Refer back to *General Information for Foundation papers and templates* for additional instructions on how to prepare your foundation papers and templates.

► Log Cabin Star Fabric Information:

The table in the next column includes yardage, fabric references, and which fabrics should go with which cutting templates to complete Unit A. This table is your guide for not only selecting your own colors, but keeping you organized. Don't forget to cut a swatch of your chosen fabric to paste in the box in the Assigned Colors column! This will help you stay organized!

► Background Fabric A1:

Step 1: Cut (16) 1-3/4" by 42" strips. Place the following strips with each Template. Stack the strips facing *right-side-up* for each template and cut (8) pieces.

(2) Strips Fabric A1, Background Template A-2



(2) Strips Fabric A1, Background Template A-3

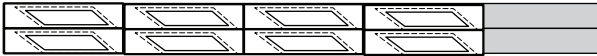

(2) Strips Fabric A1, Background Template A-6



(3) Strips Fabric A1, Background Template A-7



(3) Strips Fabric A1, Background Template A-10



(4) Strips Fabric A1, Background Template A-11

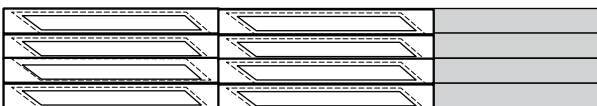

Step 2: Paper clips are used to keep the fabric and template pieces together. Place the fabric pieces with the templates in Bag 1.

► Accent Fabric A2:a

Step 1: Cut (1) 3" by 42" strip. Position the strips facing *right-side-up*. The *Unit A Accent Template A-1 Layout Sheet* is used to cut (8) pieces.

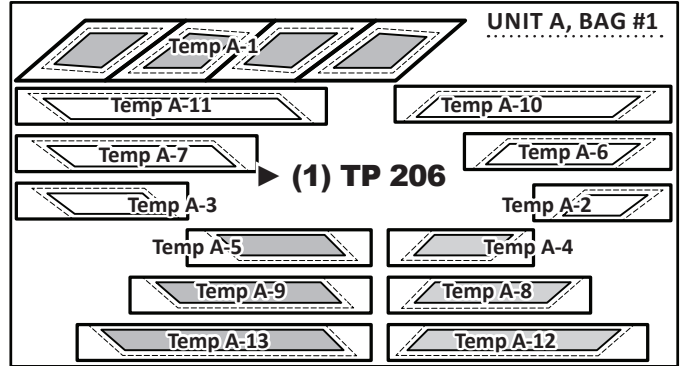
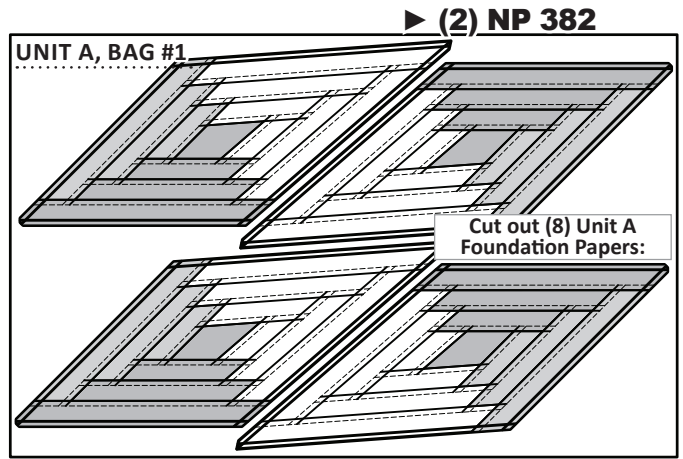

Unit A Yardage: Make (8)		
COLOR GROUP-A FABRIC #	YARDAGE INCH	ASSIGNED COLOR
Background Fabric A1 Unit A (Temp A-2, A-3, A-6, A-7, A-10, A-11)	7/8 yd or (28")	FABRIC SWATCH
Accent Fabric A2:a Unit A (Temp A-1)	1/8 yd or (3")	FABRIC SWATCH
Accent A2:b, A2:c Unit A (Temp A-4, A-5)	1/4 yd or (7")	FABRIC SWATCH
Accent A2:d, A2:e Unit A (Temp A-8, A-9)	3/8 yd or (8-3/4")	FABRIC SWATCH
Accent A2:f Unit A (Temp A-12)	1/4 yd or (5-1/4")	FABRIC SWATCH
Accent Fabric A2:g Unit A (Temp A-13)	1/4 yd or (7")	FABRIC SWATCH

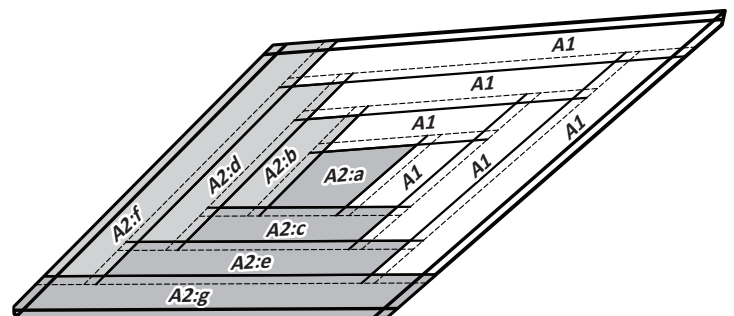

STAR BORDER: GROUP B: BAGS 2 AND 3 CUTTING INSTRUCTIONS

► Foundation Papers and Templates:

Step 1: Cut out (8) Unit B and Unit C Foundation Papers from the NP Sheet, along with (1) of each of the Background and Accent Template Layout Sheets included on the TP Sheet. See the newsprint graphics below for information on how to organize your units and templates into bags. *Refer back to General Information for Foundation papers and templates for additional instructions on how to prepare your foundation papers and templates.

► (2) NP 383

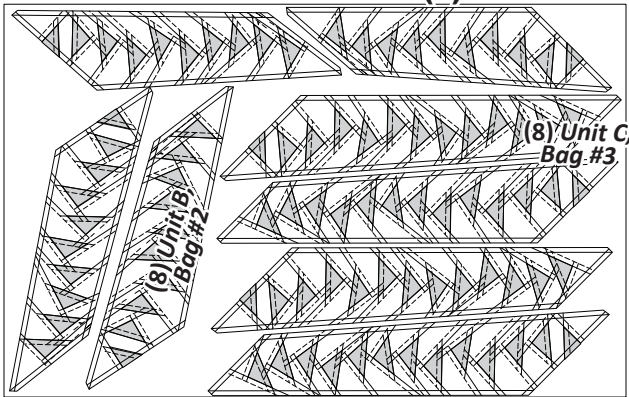

► (1) TP 207

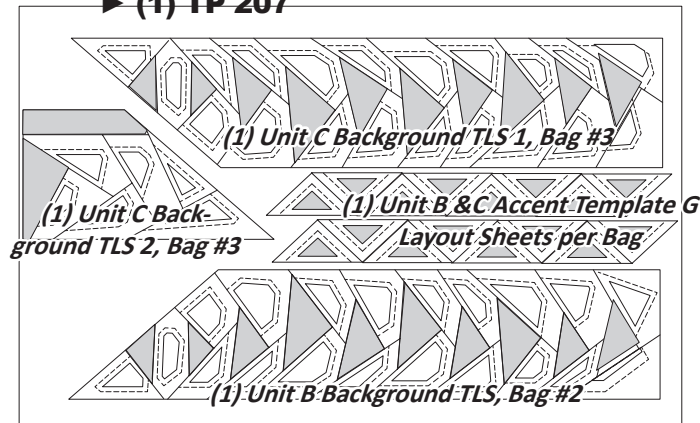

► Flying Geese Fabric Information:

The table in the next column includes yardage, fabric references, and which fabrics should go with which cutting templates to complete Units B and C. This table is your guide for not only selecting your own colors, but keeping you organized. Don't forget to cut a swatch of your chosen fabric to paste in the box in the Assigned Colors column! This will help you stay organized!

► Fabric B1:

Step 1: Cut (16) 6-1/2" by 42" strips. Stack the strips facing *right-side-up* into two stacks with (8) strips.

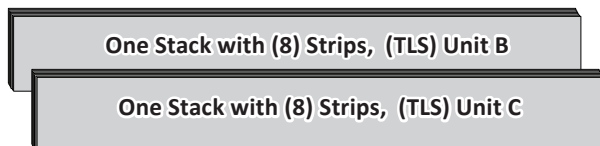

Unit B Yardage: Make(8)

COLOR GROUP-B FABRIC #	YARDAGE INCH	ASSIGNED COLOR
<u>Background Fabric B1</u> Unit B, Unit C (TLS B, C1, C2)	<u>3 yd</u> or (104")	FABRIC SWATCH
<u>Accent Fabric B2</u> Unit B, Unit C (Temp G)	<u>7/8 yd</u> or (27")	FABRIC SWATCH

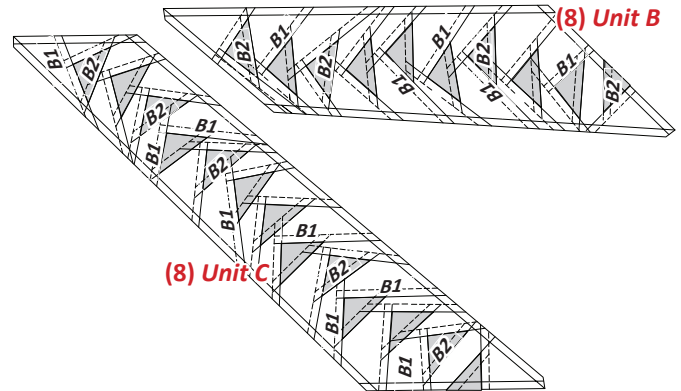

Step 2: The *Unit B Background Template Layout Sheet* is used to cut (8) pieces.

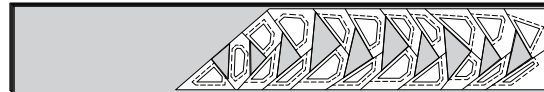

Step 3: The cutting is completed by slicing through the paper on each cut line to separate the individual sections. Paper clips are used to keep the fabric and template pieces together. Place these pieces into the bag with the *Unit B Foundation Papers*. Then, place into Bag #2.

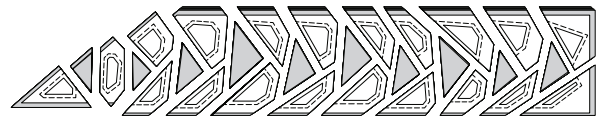

Step 4: The *Unit C Background Template Layout Sheets 1 and 2* are placed onto the strips as shown. Cut (8) pieces for each Template Layout Sheet.

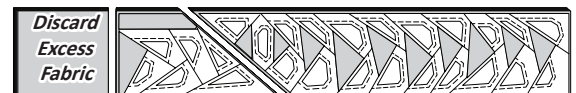
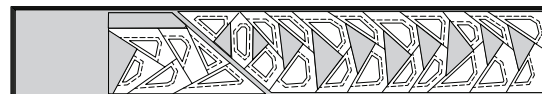

Step 5: The cutting is completed by slicing through the paper on each cut line to separate the individual sections. Paper clips are used to keep the fabric and template pieces together. Place these pieces into the bag with the *Unit C Foundation Papers*. Then, place into Bag #3.



Step 5: The cutting is completed by slicing through the paper on each cut line to separate the individual sections. Paper clips are used to keep the fabric and template pieces together. When the cutting is complete place the pieces into the Bag 7.



► **Fabric D2:**

Step 1: Cut (6) 9" by 42" strips. Divide the strips into (2) stacks, facing *right-side-up*.



Step 2: The *Unit P Accent Template Layout Sheet* is used to cut (8) pieces from the **first (3) strips**. Stack the pieces under the layout sheet and complete the cutting by cutting apart on the cut lines, in order.

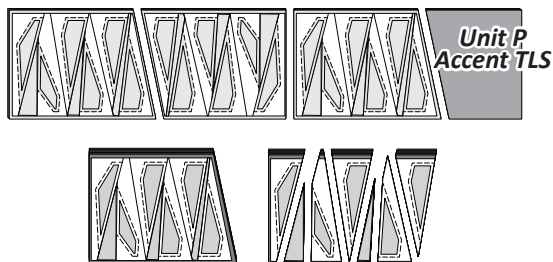

Step 3: Clip the pieces for each section together and place with the foundation papers for Unit P in Bag 6.

Step 4: The *Unit Q Accent Template Layout Sheet* is used to cut (8) pieces from the **next (3) strips**. Stack the (8) pieces under the layout sheet and complete the cutting. When you are done clip the pieces together and place with the foundation papers for Unit Q in Bag 7.

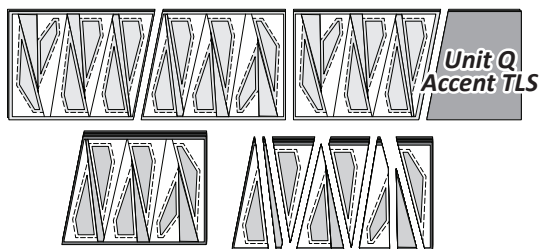

► **Fabric D3:**

Step 1: Cut (1) 7" x 42" strip. Then use the *Unit P Accent Template P-14* and *Unit Q Accent Template Q-14* to cut (8) pieces using each template. Stack the pieces under the layout sheet and complete the cutting.

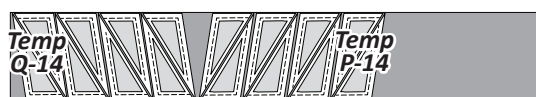

Step 2: Clip the pieces for each template and place them into Bags 6 and 7 for Unit P and Unit Q, respectively.



► **Stacking: Unit P and Q:**

The stacking process is a prerequisite to chain piecing. Position the templates and fabric pieces in numerical order facing *right-side-up*, with the *sew-sides* aligned at the top. Sec. 1 does not have a sew side.

Stacking: Both units are stacked the same way so only showing the stacked version for Unit P is shown. The stacking process begins with the largest Sec. # on the bottom. The pieces are stacked in reverse order finishing with Sec. 1 on top.

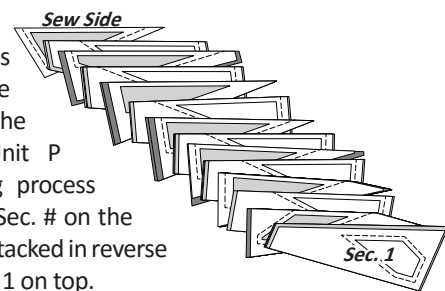

► **FOUNDATION PAPER PIECING: BORDER**

► **Border Unit P:**

NOTE - Tracing the Dashed Lines: Optional!

Step 1: Position the first piece of fabric for Sec. 1 *wrong-side-up* on your table. Lift the foundation paper, slide the fabric under Sec. 1 glue is used to adhere the fabric to the backside of the paper. Repeat Step 1 for each of the foundation units for the borders.

NOTE - Fabric Placement: The wrong-side of the fabric is against the backside of the paper.

Step 2: Place the fold template over the top of Sec. 1. Line the edge up with the solid black line marked Line 1.

Step 3: Fold the paper back over the top of the fold template.

Step 4: Place the *Add-A-Quarter* ruler next to the folded back paper, trim the fabric with the rotary cutter.

Step 5: Place the fabric for Sec. 2, *right-side-up* next to the folded back paper as shown.

Step 6: Lift the foundation paper, slide the fabric under Sec. 2. Line the sew-side up with the trimmed seam allowance. Repeat the process on each foundation paper before moving on.

Celestial Snowfall

Snowfall Tree Skirt Collection

Seasonal ❄️ ⚓ Portraits

62" Octagon

TIMELESS TREASURES 

JNQ 193P

NP 382: 2 Pages
NP 383: 2 Pages
NP 384: 2 Pages
NP 385: 4 Pages
TP 206: 1 Page
TP 207: 1 Page
TP 208: 1 Page
TP 209: 1 Page

FABRIC ID	GROUP FABRIC #	Yds by Unit	Yds by Fabric*	SKU
Fabric Group A				
Blue/Beige Crystals	A1 A2:d, A2:e	7/8 Yd 3/8 Yd	1-1/8 Yd (36-3/4")	JN-C3706 White
Red Snowflake	A2:a B2	1/8 Yd 7/8 Yd	7/8 Yd (30")	JN-C3712 Red
Grey Snowflake	A2:b, A2:c	1/4 Yd	1/4 Yd (7")	JN-C3712 Grey
Blue Ice	A2:f C2:a	1/4 Yd 3/8 Yd	1/2 Yd (16-1/4")	JN-C3711 Ice
Turquoise Lake	A2:g C2:b	1/4 Yd 3/8 Yd	5/8 Yd (18")	JN-C3705 Turq
White Crystals	B1 C1 C3 D2 D3	3 Yds 1-7/8 Yds 1/4 Yd 1-7/8 Yds 1/4 Yd	6-7/8 Yd (242")	JN-C3714 White
Beige Crystals	D1	2 yds	2 Yds (68")	JN-C3700 Cream
Backing/(JN-C3711 Ice)		4 yds		As Desired
Binding		3/4		JN-C3712 Red
Batting (90" Wide)		2		Hobbs 80/20

► GROUP LAYOUT

- Group A:** Center Star
- Group B:** Star Border
- Group C:** Star Background
- Group D:** Border

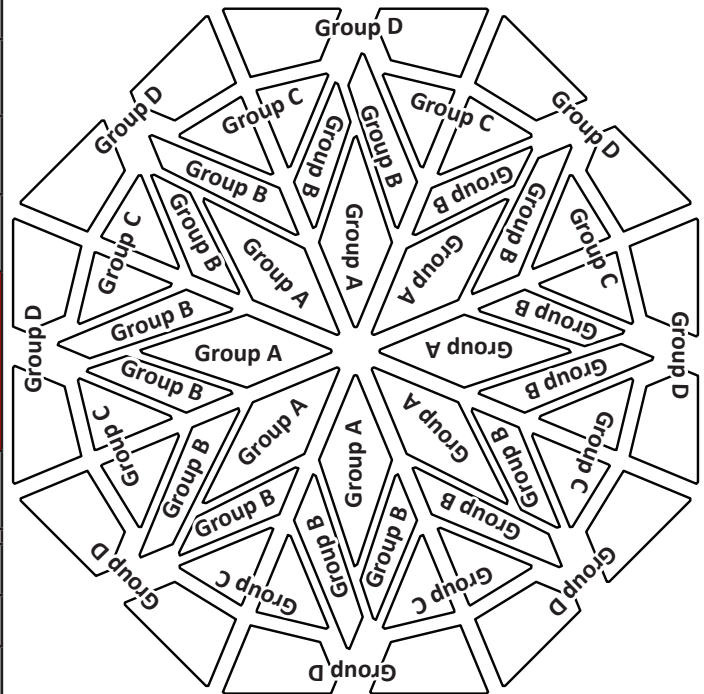

► Quiltster Compatible

Quiltworx.com has collaborated with a new company called Quiltster to bring you a fabric auditioning mobile application for our designs. Quiltster will launch to a consumer audience in early 2016 with a layout for **Celestial Snowfall** that can be colored with your own fabric swatches to preview your quilt before you make it! To get on the mailing list for Quiltster updates, visit Quiltster.com!



**Yardage by Fabric is sometimes less than by the unit as the Unit Yardage is rounded up to the nearest 1/8th Yard at the unit level, whereas Yardage by Fabric is added up in inches, then rounded to the nearest 1/8th of a yard at the end. If a fabric is at or very close to a nearest 1/8th, we rounded up another 1/8th (Turq Lake and White Crystals). Conserving Yardage can be accomplished by repeating fabrics.*

NOTE - More Information on yardage: Block and color layouts for each unit are provided with cutting instructions throughout the pattern.

Visit us on:



© Copyright: April 2015
Pattern: Celestial Snowfall

All rights reserved. No part of this pattern can be reproduced in any form for any commercial purpose without the expressed written permission of Judy Niemeyer Quilting. The written instructions, foundation papers, graphics, and photographs for this pattern were designed as a package for the purpose of retail sales and as a result, fall under the protection of the federal copyright laws of the United States of America. Extra materials may be obtained from local quilt shops or directly from Judy Niemeyer Quilting aka Quiltworx.com.

Quiltworx.com
Judy Niemeyer Quilting

E-mail: info@quiltworx.com • Web: www.quiltworx.com



Print Date: 01-21-16