

This layout has been designed so that the way you sew the sashing templates on changes between Rounds. The reason for the change is to minimize the number of matched seams in the assembly process.

Also, pay attention to the position of your Fabric #s before sewing the sashing strips onto the diamonds. It is important that you begin the sewing rotation when adding the sashing with Fabric #1 at the bottom on the left hand corner (as shown in Step 1, below).

The Unit AA Diamond Blocks in Round A and Round C are sewn the same way. The Diamond Blocks sewn for Round B later in the pattern will be sewn in a different manner. Follow these steps and graphics to add the sashing to your AA Diamond Blocks.

Round A and Round C: Reference the *Sashing Assembly Graphic*.

Step 1: Layout the Diamond Blocks with the sashing pieces as shown for Step 1. The short sashing strips, T-Template AA-1A and AA-2A, are placed along the edges at the top and bottom of Row 1 and Row 4. Make sure the diamond position for S1 is in the bottom left corner. The longer strips are positioned along the sides.

► Sashing Assembly Instructions: Round A, T-Template AA-1A to AA-4A, Bag #AA-1 and Round C, T-Template AA-1C to AA-4C, Bag #AA-2

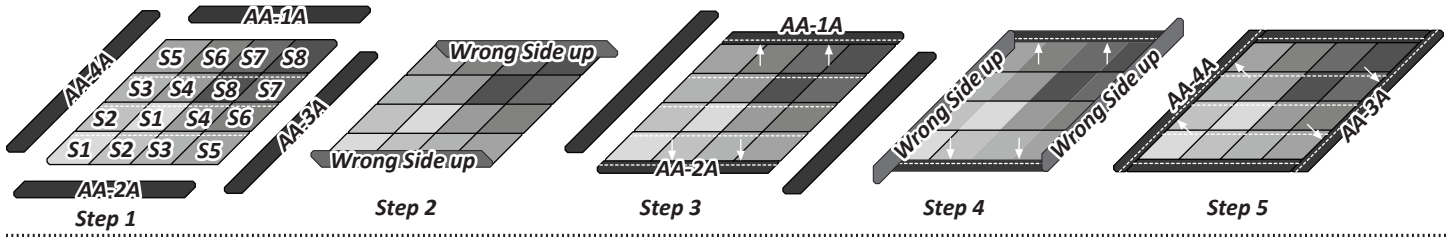

GROUP A: CHAPTER TWO, UNIT AB FOUNDATION PAPERS AND TEMPLATES:

Ziploc Storage Bags: You will need (2) Bags to complete the organization for these instructions. Label each bag as follows.

- Bag #AB-1, Unit AB, Round C (:a Fabrics)
- Bag #AB-2, Unit AB, Round B (:b Fabrics)

► Preparing the Foundation Papers:

Cut out (8) of each *Foundation Sheet AB1, AB2, AB3, and AB4* found on [NP 577]. Cut out the associated *AB Strip Piecing Templates* and *T-Template Layout Sheets* found on [TP 381]. See the newsprint below for information on how to organize your units and templates into bags. *Refer back to General Information under Foundation Papers and templates for additional instructions on how to prepare your foundation papers and templates.

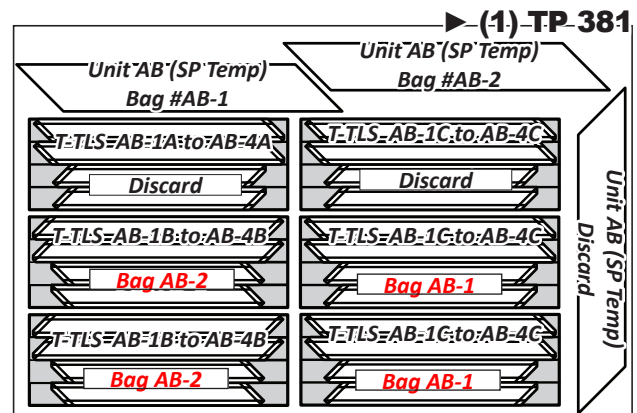
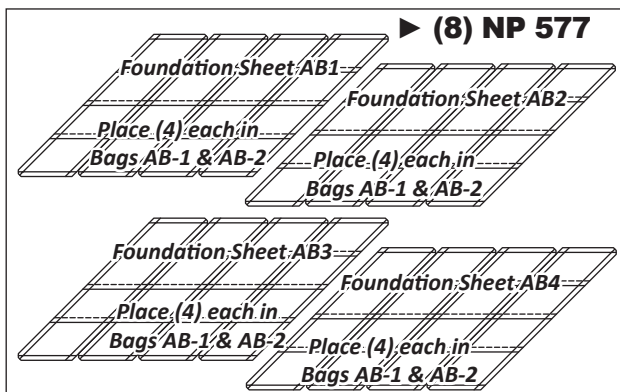

You should have the following papers in each Bag. You can discard the (2) left over T-Templates at this time, as you will not need them to complete the AB Units.

- Bag #AB-1: (4) of each Foundation Sheet AB1-AB4, (1) SP Template, (2) each T-Template Layout Sheets AB-1C to AB-4C.
- Bag #AB-2: (4) each Foundation Sheet AB1-AB4, (1) SP Template, (2) each T-Template Layout Sheets AB-1B to AB-4B.

Diamond Fabric #s: The fabric numbers assigned to the AB Units are different than the previously assigned numbers for Unit AA. These papers were assigned (16) Fabric #s instead of (8). Working with (16) fabric numbers opens the door to more options when playing with color. The biggest advantage is the ability to repeat any color an odd number of times. Cutting and stacking instruction for these papers have also changed, pay attention to the instructions as you cut, stack, and piece the Units. The Unit Block Fabric Layout provided on the next page shows the location of each assigned Fabric # for Unit AB.

FABRIC INFORMATION: GROUP A

The Diamond Blocks are divided into (2) Color Groups that make (16) blocks each. Color Group AB:a is assigned to the papers in Bag AB-1, Color Group: AB:b is assigned to the papers in Bag #AB-2. If you are uncertain on how to lay out your colors, note the shading in the diamonds below match the shading of the Diamond blocks in the cover quilt. Also, a table is provided below that shows you how many strips to cut of each fabric. The Kitting Sheet and table below use an signifier of "AB-" in front of each S1. This signifies which diamond block the strips go with in the overall yardage chart. The AB- is dropped after this point in these instructions to simply the fabric references.

- **Fabrics AB-S1:a-AB-S16:a:** These fabrics are used to complete the (16) Diamond Block Units in **Round C**.
- **Fabrics AB-S1:b-AB-S16:b:** These fabrics are used to complete (16) of the Diamond Block Units in **Round B**.

Color Group:a
AB-S1:a to AB-S16:a
Bag AB-1
Make (16)

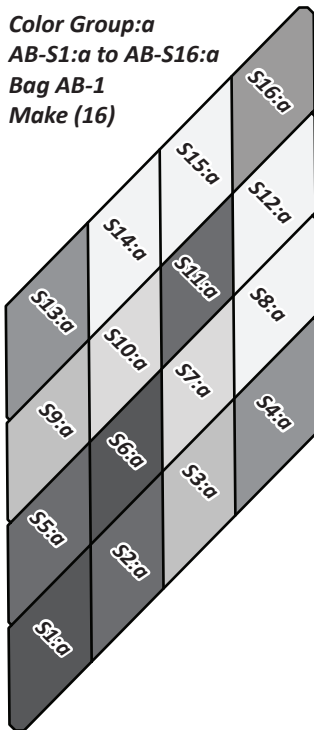

AB:a FABRIC REF: #	2-1/2" Strips	AB:a Fabric Ref. #	2-1/2" Strips
S1:a	2	S9:a	2
S2:a	2	S10:a	2
S3:a	2	S11:a	2
S4:a	2	S12:a	2
S5:a	2	S13:a	2
S6:a	2	S14:a	2
S7:a	2	S15:a	2
S8:a	2	S16:a	2

Color Group:b
AB-S1:a to AB-S16:b
Bag AB-2
Make (16)

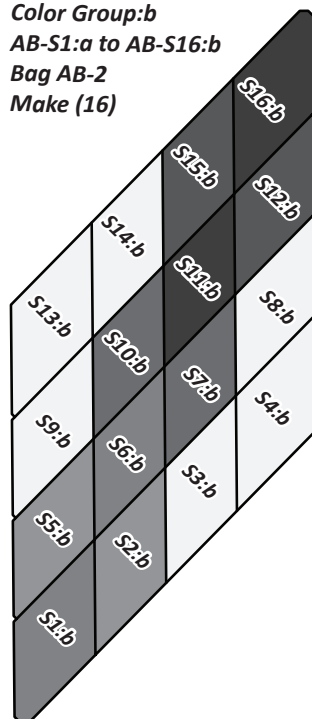

AB:b FABRIC REF: #	2-1/2" Strips	AB:b Fabric Ref. #	2-1/2" Strips
S1:b	2	S9:b	2
S2:b	2	S10:b	2
S3:b	2	S11:b	2
S4:b	2	S12:b	2
S5:b	2	S13:b	2
S6:b	2	S14:b	2
S7:b	2	S15:b	2
S8:b	2	S16:b	2

- **Fabric AB-A1:** This fabric is used to cut the pieces for the sashing, strips sewn around the AB Diamond Block Units in both **Round B** and **Round C**.

Diamond AB, Sashing Unit Chart, Fabric AB-A1 (Make 32 total Diamonds)			
FABRIC #	INCH	YDS	ASSIGNED COLOR
Sashing Fabric AB-A1 Place 11 Strips in Bag #AB-1			
FABRIC AB-A1 T-TLS AB-1B to AB-4B T-TLS AB-1C to AB-4C	Cut (11) Strips 5" by 42"	55" or 1-5/8	FABRIC SWATCH

► Unit Block Fabric Layout

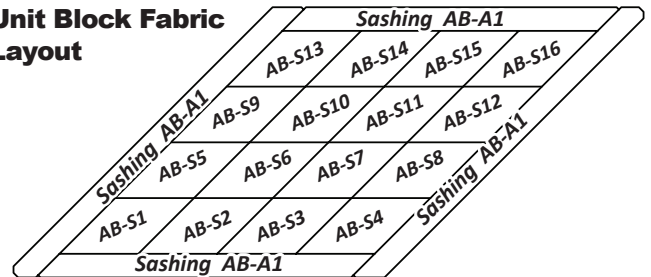

► Choosing your Own Colorway

Each bag includes enough strips and paper to complete (16) Diamond Blocks. The cutting instructions are the same for each bag. If you choose to use a different arrangement of fabrics for your blocks, first audition your fabric on the Color Group Layouts provided in the previous column (or use Quiltster!). Then, cut (2) 2-1/2" by 42" strips for each diamond section assigned to each Fabric #. A small fabric swatch cut and pasted onto each diamond will help to keep your fabric strips organized in the cutting, stacking, and sewing process. You will need to think about how to adapt the following cutting instructions for your specific colorway as the following instructions assume you will be working with the same fabric layout that we have designed for our cover quilt.

COLOR GROUP AB:a, BAG #AB-1

► Foundation Sheet AB1:

Step 1: Cut (2) 2-1/2" by 42" strips from each Fabric S1:a-S4:a if you have not already done so. (Remember, these are Fabric AB-S1:a to AB-S4:a. The "AB-" identifier has simply been dropped.)

Cut & Stack (2) 2-1/2" by 42" Strips, Fabric S4:a

Cut & Stack (2) 2-1/2 by 42" Strips, Fabric S3:a

Cut & Stack (2) 2-1/2" by 42" Strips, Fabric S2:a

Cut & Stack (2) 2-1/2" by 42" Strips, Fabric S1:a

Step 2: Press and stack the strips facing **right-side-up** in descending order starting with Fabric S4 on the bottom finishing with S1 on the top.



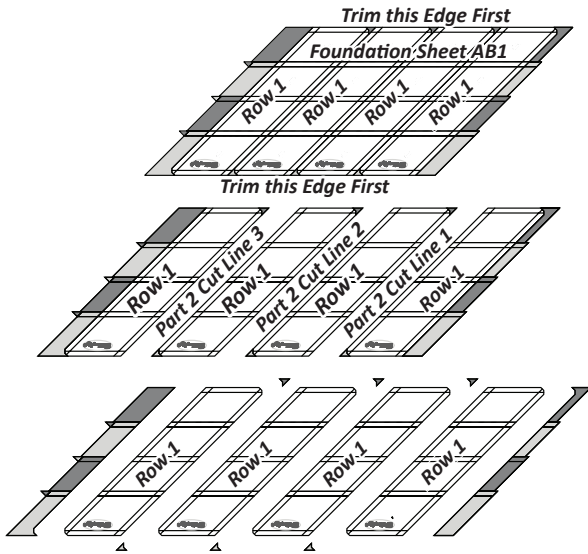

Step 6: Position Row-4 onto Row-3, right-sides-together. Pin at each cross-section, then remove the papers under Row-3. Sew the strips together with Row-3 next to the feed dogs.

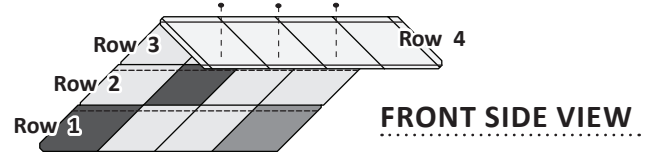

Step 7: To finished the star, remove the foundation papers from under Row-4 and press the seam towards Row-3.

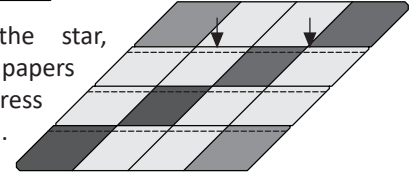

CUTTING: BAG #AB-1 AND AB-2: SASHING

Fabric AB-A1

Step 1: Cutting instructions were provided in the Unit Chart on Page 11 for the sashing. You should have (11) 5" by 42" strips between Bags #AB-1 and #AB-2. If you have not cut these strips yet, please do so at this time.

Cut (11) 5" by 42" Strips, Fabric AB-A1

Step 2: Stack the strips facing *right-side-up* into (2) stacks and subcut (32) 5" by 14" rectangles (you will have leftover fabric on one strip). Stack the rectangles into (4) stacks of (8) pieces.



Step 3: Remove both T-TLS AB-1B to AB-4B from Bag #AB-2 and T-TLS AB-1C to AB-4C from Bag #AB-1. Eight (8) fabric pieces are stacked under each T-Template Layout Sheet as shown below (and at the top of the next column). You will have (2) stacks for each T-Template. Trim the excess fabric around the perimeter of each T-TLS to ensure the proper width. Large paper clips are used to secure the T-TLS to your fabric before you cut. Use your rotary cutter to separate the templates on Cut Lines 1 through 3. Trim the shaded area of the paper and excess fabric away along both ends to complete the cutting for the length. Then, trim the smart corners. Accurate trimming is necessary to preserve the Smart Corners. Place the pieces with each T-Template into the Bags as noted below.

T-Templates AB-1B to AB-4B

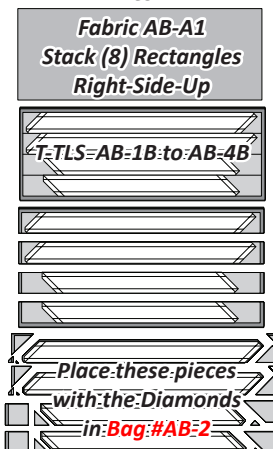

T-Templates AB-1B to AB-4B

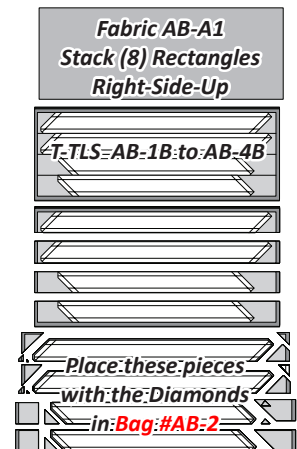

ASSEMBLE THE DIAMONDS

Step 1: The rows are joined now to complete the diamonds for each Color Group in Bags AB-1, and AB-2 into the order they will be sewn together. One, each, of Rows 1, 2, 3, & 4 are joined to complete (16) diamonds.

FRONT SIDE VIEW

Build (16) Diamonds

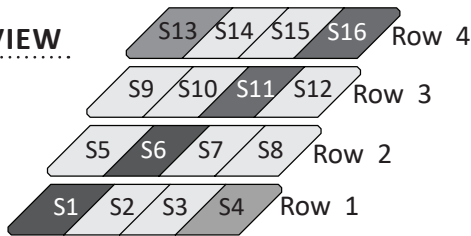

Step 2: Position Row-2 onto the top of Row-1, with both strips facing right-sides-together. Row-1 is placed on the bottom and Row-2 on the top. Match and pin each intersection where the sew lines cross on your foundation paper. Once the pieces are pinned together, remove the foundation papers from under the diamond sections on Row-1 without disturbing the pins.

RIGHT SIDES TOGETHER

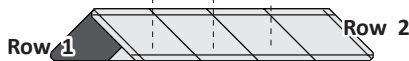

Step 3: Place Row-1 on the bottom next to the feed dogs, leaving Row-2 on top, when sewing the strips together. Press the seams towards Row-1.

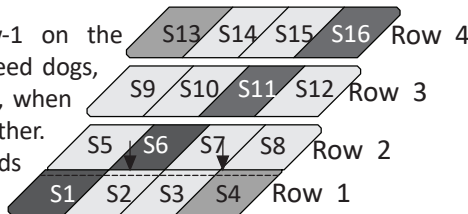

Step 4: Position Row-3 on top of Row-2, with right-sides-together. Pin at each cross-section, then remove the paper under Row 2.

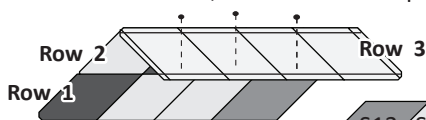

Step 5: Position Row-2 next to the feed dog, sew the strips together and press the seam towards Row-2.

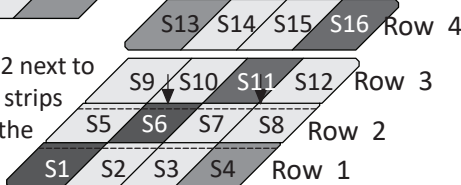

► **T-Templates AB-1C to AB-4C**

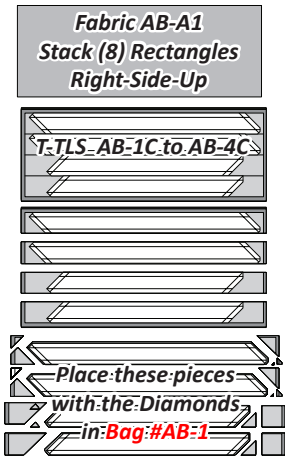

► **T-Templates AB-1C to AB-4C**

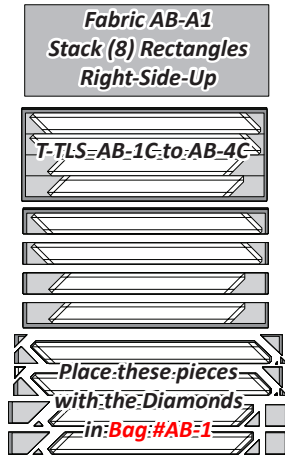

Round B: Reference the *Sashing Assembly Graphic*, below.

Step 1: Layout the Diamond Blocks with the sashing pieces as shown for Step 1. The short sashing strips, T-Template AB-1B and AB-2B, are placed along the edges on the right and left side of the diamond. Make sure the diamond position for S1 is in the bottom left corner. The longer strips are positioned along the top and bottom.

Step 2: Position the left and right sashing pieces wrong-side-up on the right side of each diamond, matching both ends of the diamond block (use the Smart Corners!). Use a glue pen to secure the edges.

Step 3: Sew the strips onto each edge. After the strips are sewn, press both seams towards the sashing.

Step 4: The long sashing strips, T-Template AB-3B and AB-4B, are sewn to the top and bottom. Position the sashing pieces wrong-side-up on the right side of each diamond matching both ends of the diamond block.

Step 5: Press both seams toward the sashing.

Round C: This time, you will sew T-Templates AB-1C and AB-2C on the top and bottom edges (Rows 1 and 4). The Templates for the sides are T-Template AB-3C and AB-4C. Press all seams towards the sashing strips.

When you are done with the sashing place the blocks back into their assigned bags.

► **Sewing the Sashing**

Step 1: The diamonds in Bag #AB-2 are assigned to Round B. The diamonds in Bag #AB-1 are assigned to Round C. Note that the shading on the diamonds is not a perfect match to any specific block on your quilt, it is just there as an example.

Step 2: The sewing order for the sashing template pieces changes between Rounds B and C, so pay attention to the graphic below as you complete the sewing for each bag. The reason for the change is to minimize the number of matched seams in the assembly process.

► **Sashing Assembly Instructions: Round B, T-Template AB-1B to AB-4B, Bag #AB-2**

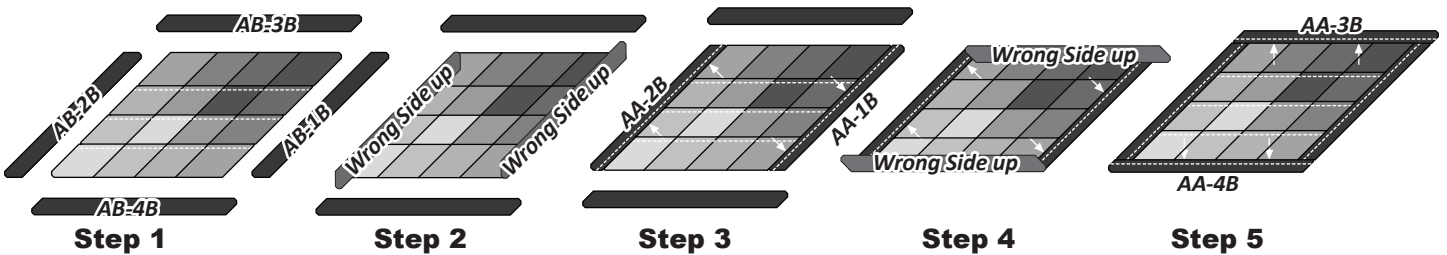

► **Sashing Assembly Instructions: Round C, T-Template AB-1C to AB-4C, Bag #AB-1**

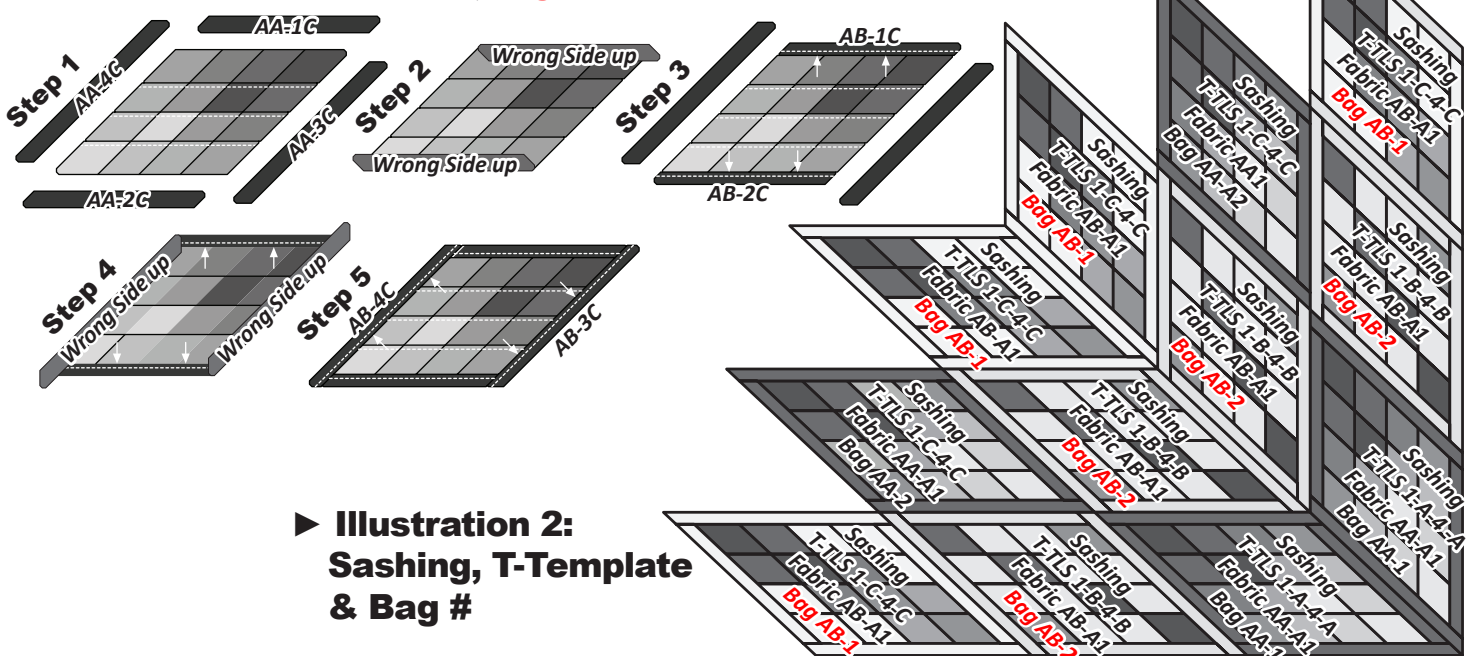

► **Illustration 2: Sashing, T-Template & Bag #**

NOTE - Fussy Cut Border Assembly: If you have made the Fussy Cut borders, they are already assembled. You will not add the border pieces as shown in Assembly Graphic 2. Instead, you will assemble the diagonal seams in Assembly Graphic 3, then add the Fussy Cut Borders.

Assembly Graphic 3 [LP 026]: Join the rows as shown to complete the (8) triangles. Press the seams to spin clockwise on the front side of the quilt.

NOTE - Fussy Cut Border Assembly: If you have made the Fussy Cut borders, they are already assembled. Complete the diagonal seams shown in Assembly Graphic 3, then sew the border on to each triangle wedge. Press the seams towards the borders.

Assembly Graphic 4 [LP 026]: Join the triangles to complete the four corner sections. Press all seams as shown.

Assembly Graphic 5 [LP 026]: Join the corner squares to complete the two half sections. Press all seams as shown.

Illustration 6: The two half sections are sewn together to complete the quilt top.

Final Pressing Direction: Before you can press the last joining seam, you will need to pick back the stitches at the intersection where the eight points intersect in the middle of the quilt. The seams are tweaked and then pressed in opposing directions. The pressing arrows on the graphic show the seams being pressed counter-clockwise on the backside of the quilt.

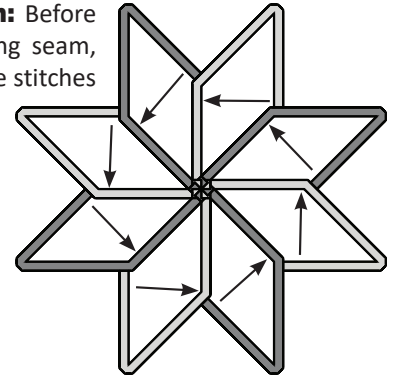

► **Block Layouts for Standard Border Assembly Option**

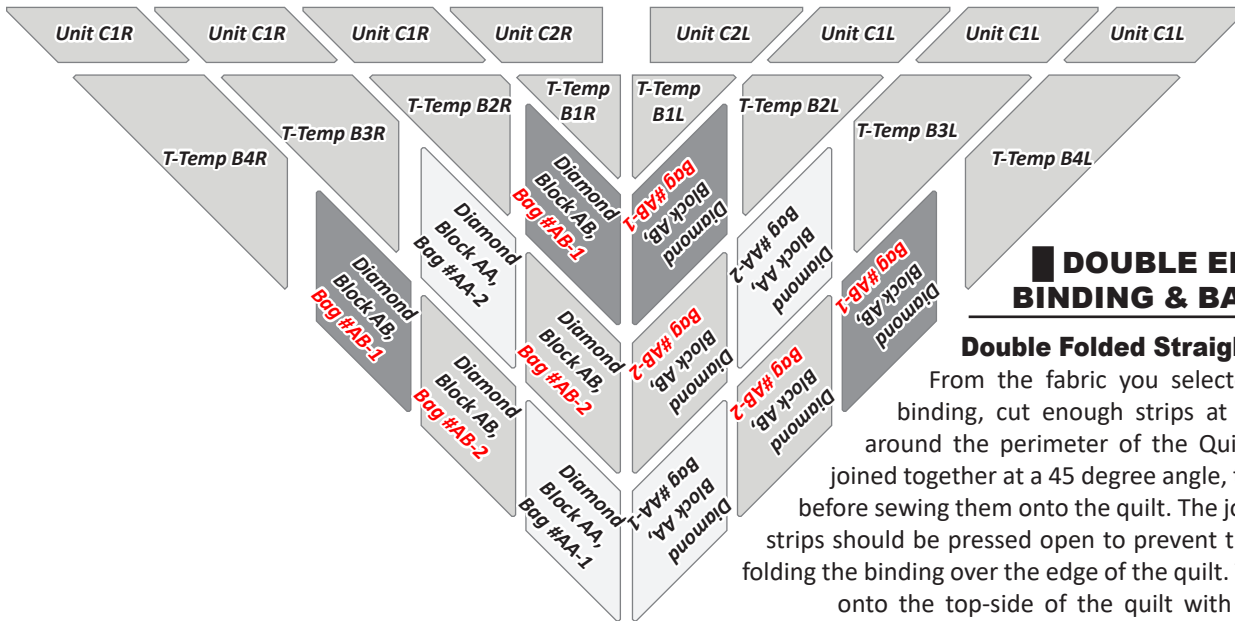

DOUBLE EDGED BINDING & BACKING

Double Folded Straight Edge Binding:

From the fabric you selected for the outside binding, cut enough strips at 2-1/2" wide to go around the perimeter of the Quilt. The strips are joined together at a 45 degree angle, then pressed in half before sewing them onto the quilt. The joining seams on the strips should be pressed open to prevent the extra bulk when folding the binding over the edge of the quilt. The binding is sewn onto the top-side of the quilt with your machine and hand stitched on the backside.

► **Block Layouts for Fussy Cut Border Assembly Option**

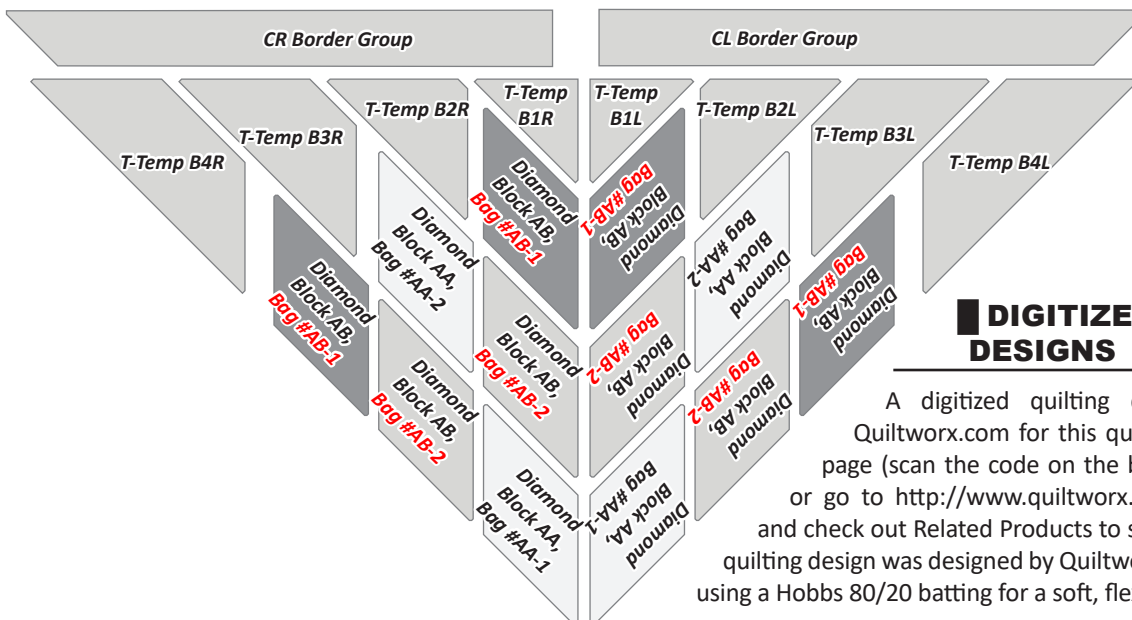

DIGITIZED QUILTING DESIGNS

A digitized quilting design is available on Quiltworx.com for this quilt! Click on the pattern page (scan the code on the back to get there quickly or go to <http://www.quiltworx.com/patterns/ice-castles> and check out Related Products to see what is available. The quilting design was designed by Quiltworx.com. We recommend using a Hobbs 80/20 batting for a soft, flexible finish.