

# GROUP B: CHUTES AND LADDERS STAR BORDER INSTRUCTIONS

**Ziploc Storage Bags:** You will need (4) bags to complete the organization for these Instructions. Label the bags as follows:

- Bag #B1: (8) Unit B1, Foundation Papers
- Bag #B2: (8) Unit B2, Foundation Papers
- Bag #B3: (8) Alternate 1 Spike, T-Temp B-1
- Temporary Bag: All Templates

## ► Preparing the Foundation Papers:

**Foundation Papers:** Cut out (8) each of Unit B1 and B2 foundation papers [NP 900 & NP 901]. Cut out (1) each of Template Layout Sheets [NP 901 & TP 712], arrange them in numerical order, then place into a temporary bag; after the fabrics have been cut, the individual Sec. Templates for the (TLS) will be placed into assigned Bag #s with their associated foundation papers. Cut out (1) of T-Template B-1 [TP 712]. Reference the newsprint graphics that follow for the location of each Unit, Template and (TLS) along with the associated Bag #. *\*Refer back to General Information for Foundation papers and templates for additional instructions on how to prepare your foundation papers and templates.*

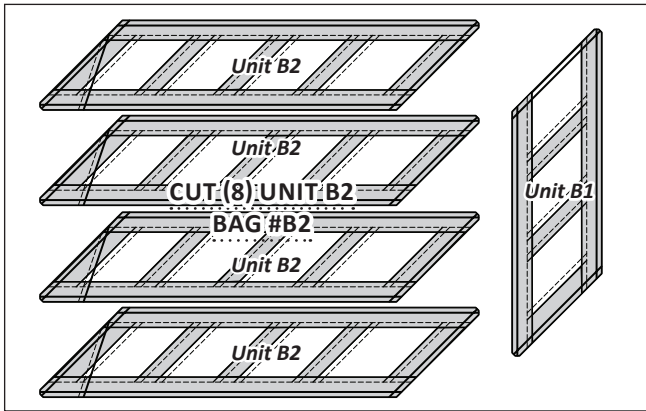
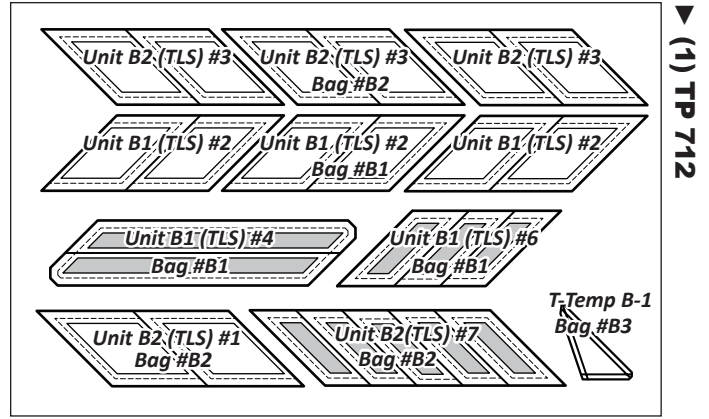

▼ (2) NP 900

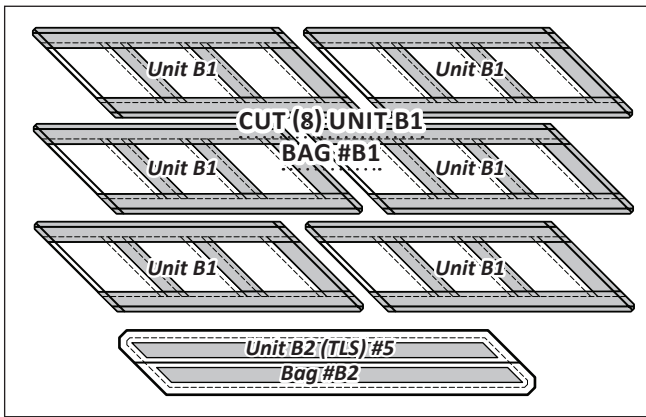

▼ (1) NP 901

## ► Chutes & Ladders Fabric Information:

The yardage chart that follows includes Fabric #s, yardage/inches, and a reference to which fabrics go with which Templates and Template Layout Sheets (TLS) to complete **Units B1 & B2**. The table is your guide for selecting colors and keeping yourself organized. Don't forget to cut a swatch of your chosen fabric to paste in the box in the Assigned Color column! A Color Layout at the top of the next page provides a visual reference of the location of each Fabric #.

Units B1 & B2 Yardage: Make (8) Each		
GROUP-B FABRIC #	YARDAGE INCH	ASSIGNED COLOR
Fabric B1 Unit B2 (TLS #1)	1/8 yd or (4")	FABRIC SWATCH
Fabric B2 Units B1 & B2 (TLS #2 & #3)	1/4 yd or (8")	FABRIC SWATCH
Fabric B3 Units B1 & B2 (TLS #2 & #3)	1/4 yd or (8")	FABRIC SWATCH
Fabric B4 Units B1 & B2 (TLS #2 & #3)	1/4 yd or (8")	FABRIC SWATCH
Fabric B5 Units B1 & B2 (TLS #4, #5, #6 & #7)	1-1/2 yds or (52")	FABRIC SWATCH
Fabric B6:a (T-Temp B-1)	1/8 yd or (4")	FABRIC SWATCH
Fabric B6:b (T-Temp B-1)	1/8 yd or (4")	FABRIC SWATCH

**Step 6:** Stack the remaining (4) 4" x 42" strips with fabric facing **right-side up**. Position **Unit B2 (TLS) #7** on the stack and cut (8) pieces matching the size and shape of the (TLS), repositioning the template as needed for each cut.

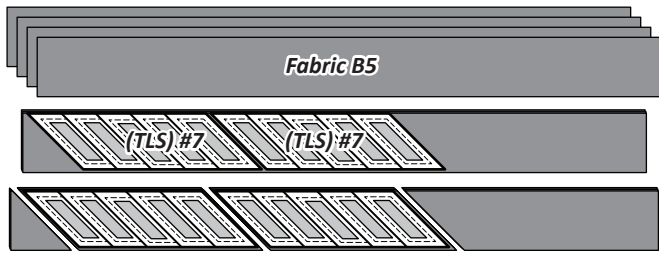

**Step 7:** Complete the cutting by slicing through the paper on each cut line in numerical order to separate the individual sections. Use paper clips to keep the fabric and template pieces together in each section. Place back into Bag #B2.

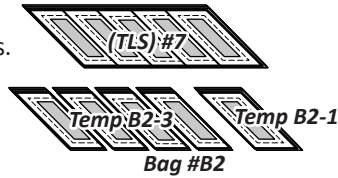

► **Fabrics B6:a & B6:b: T-Temp B-1**

**Step 1:** Cut (1) 4" by 42" strip from **each Fabric B6:a and B6:b**. Place the strips facing **right-side up** and position **T-Temp B-1** on top. Cut (4) pieces matching the size and shape of the T-Template from each fabric. Be sure to cut the Smart Corners accurately. **Stack the pieces with Fabric B6:a on top and B6:b on the bottom.**



**STACKING: UNIT B1, BAG #B1**

**Stacking:** The stacking process is a prerequisite to chain piecing. Pieces are stacked in reverse numerical order finishing with **Sec. 1** on top. **Fabrics B2 through B4** will be used as shown for template B1-2. Position the templates and fabric pieces for Unit B1 facing **right-side up**, with the **Sew Sides** aligned at the top. (Sec. 1 does not have a Sew Side.) Begin the stacking process with **Sec. 8** on the bottom. Continue stacking pieces in the sewing order, interspersing (3) stacks of B1-2 for sections 2, 4, and 6, and finishing with **Sec. 1** on top.

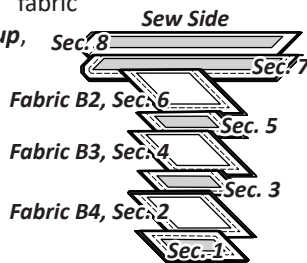

**FOUNDATION PAPER PIECING: UNIT B1**



**NOTE - Tracing Dashed Lines:** Trace the dashed lines printed on the front side of the foundation paper onto the backside of the paper.

**Step 1:** Position the first piece of fabric for **Sec. 1 wrong-side up** on your table. Lift the foundation paper, and slide the fabric under **Sec. 1**. Use glue to adhere the fabric to the **backside** of the paper. Repeat Step 1 for each foundation paper before moving on to Step 2.



**NOTE - Fabric Placement:** The wrong-side of the fabric is against the backside of the paper.

**Step 2:** Place the fold template over the top of **Sec. 1**. Line the edge up with the solid black line marked **Line 1**. Fold the paper back over the top of the fold template.

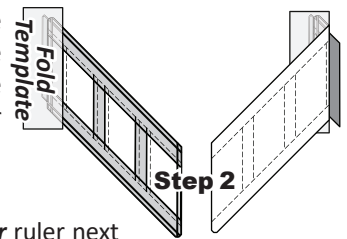

**Step 3:** Place the **Add-A-Quarter** ruler next to the folded-back paper, and trim the fabric with the rotary cutter.

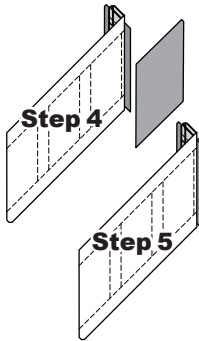
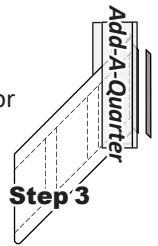

**Step 4:** Place the fabric piece for **Sec. 2 right-side up** next to the folded-back paper.

**Step 5:** Lift the paper, and slide the fabric under **Sec. 1**, lining the sew-side up with the trimmed seam allowance. Repeat **Steps 2-5** for each foundation paper before moving on to Step 6.

**Step 6:** Open the paper and sew on **Line 1**. The stitches should start and stop about 1/8" past the beginning and the end of each stitch line. Complete the sewing on each unit before moving on to the next step.

**Step 7:** Loosen the glue under **Sec. 1**, then press the fabric pieces open on the backside of each paper.



**Repeating Steps 2-7:** Continue adding the remaining fabric pieces to each section up through **Sec. 6** on the foundation papers.



**Step 8:** Position the fold template over the top of **Sec. 1-6**, lining the edge up with **Line 6**.

**Step 9:** Fold the paper back and tear the paper along the stitches on **Lines 1-5**. Stop tearing when you hit the fold template.

**Step 10:** Trim the fabric with the **Add-A-Quarter** ruler.

**Step 11:** Position **Sec. 7** fabric piece **right-side up** next to the paper. Lift the paper and slide the fabric under **Sec. 7** in position.

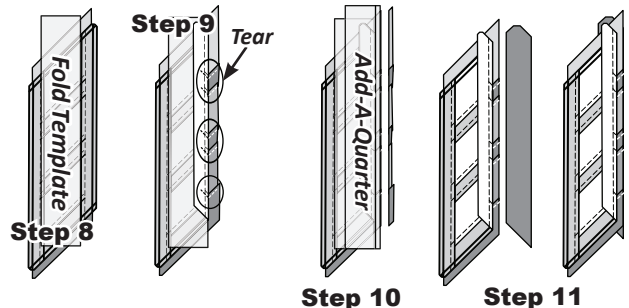

**Step 12:** Open the paper, sew on **Line 6**, and press open.