

**► Rainbow Cutting: Group J, K, and L (Fabrics RB1 to RB8)**

**Step 1:** You will need to find and cut out the following templates for Group J, K, and L before you can complete the cutting for the (8) remaining strips in Step 6 below. Reference NP 747, on Page 7 for Group J, NP 863 and 864 on Page 10 for Group K, and the Group L Strip Piecing Template Insert:

- Group J, Newsprint NP 747: TLS #2 and #3
- Group K, Newsprint NP 863: TLS #3, #5, & #7
- Group K, Newsprint NP 864: TLS #6 and #8
- Group L, Alternate Strip Piecing Templates (Insert)

**Step 2:** TLS #3, #5, #6, #7, and #8 from Group K must be cut apart before you can complete the next step. Cut the TLS apart on Cut Line #1. You only need (1) of the remaining templates, so set the second template aside.

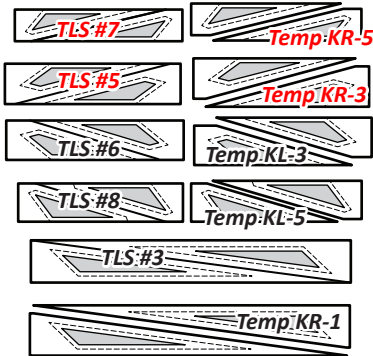

**Step 3:** Open, and press the 6" Rainbow Fabric RB1 to RB8, set aside from the cutting on Page 6. Stack the fabrics facing, Right-Side-Up, starting with Fabric RB8 (Pink) on the bottom in reverse order, ending with RB1 on the top.

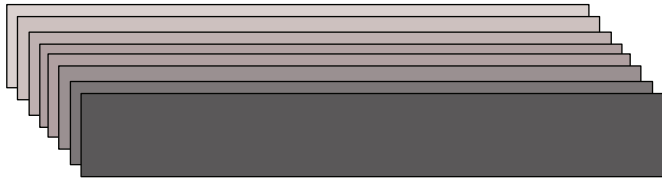

**Step 4:** Arrange the Templates and Template Layout Sheets for Groups J, K, and L on the rainbow fabric stack as shown.

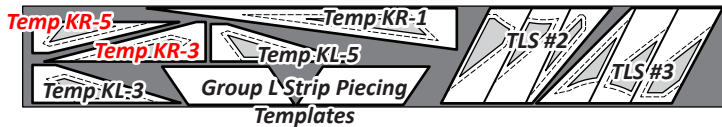

**Step 5:** Cut the stacks apart as shown. You do not need to cut on any additional Cut Lines at this time. Those instructions will be provided in the individual Group Instructions. Put the J TLS Stacks into the Group J Bag, the K Templates into the Group K Bag, the L Strip Piecing Template stacks into the Group L Bag. Then, continue on with the instructions working through each group, one at a time.



**GROUP J: WIND SPINNER INSTRUCTIONS**

**Ziploc Storage Bags:** You will need (2) additional bags to for to complete the organization for these instructions. Label the bags as follows to stay organized while cutting the Foundation Units and Templates.

- Bag #J1: (8) Unit J1 Papers
- Bag #J2: (8) Unit J2 Papers

**► Preparing Foundation Papers & Templates:**

**Newsprint:** Cut out (8) ea. Unit J1 & Unit J2, [NP 747 & 748]. Place these papers into their assigned Bag #s listed above then place with the Group J Bag. The Templates and Template Layout Sheets (TLS) are temporarily placed into the J Group Bag. After the fabric has been cut the individual Sec. Temp's and (TLS) are placed into their assigned bags with their associated foundation papers. See the newsprint graphics that follow for information on how to organize your units and templates into bags. \*Refer back to General Information for Foundation papers and templates for additional instructions on how to prepare your foundation papers and templates.

**► (1) NP 747**

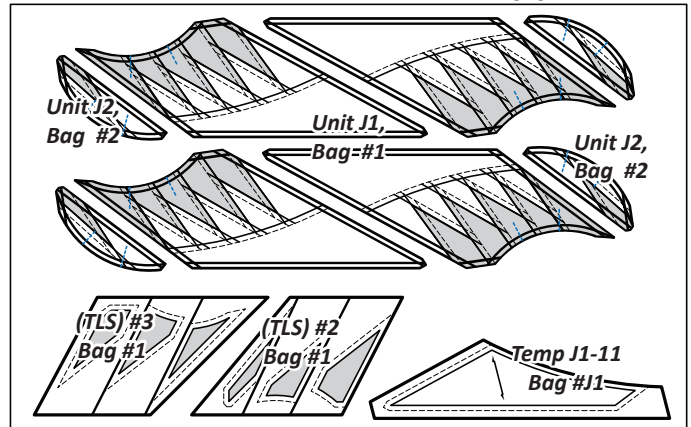

**► (1) NP 748**

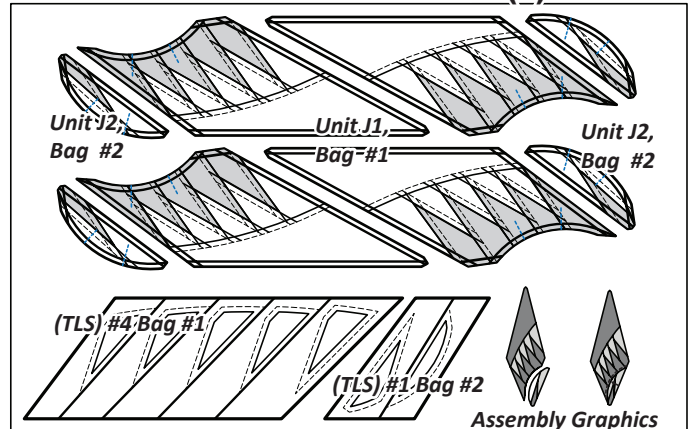

## GROUP K: DAGGERED TOP INSTRUCTIONS

**Ziploc Storage Bags:** You will need (2) additional bags to complete the organization for these instructions. Label the bags as follows to stay organized while cutting the Foundation Units and Templates.

- Bag #K1: (8) Unit KR papers, and Unit KR cutting templates
- Bag #K2: (8) Unit KL papers, and Unit KL cutting templates

### ► Preparing Foundation Papers & Templates:

Cut out (8) ea. Unit KR & Unit KL [NP 863 & NP 864]. Place these papers into their assigned Bag #s listed above then place with the Group K Bag. The Unit KR and Unit KL Template Layout Sheets (TLS) #1, #2, and #4 are temporarily placed in the K Group Bag (TLS #3, and #5 to #8 were cut all ready per instructions on Pages 6 and 7). After the fabric has been cut, the individual Sec. Templates for the (TLS) are placed into assigned Bag #s with their associated foundation papers. See the newsprint graphics that follow for information on how to organize your units and templates into bags. \*Refer back to General Information for Foundation papers and templates for additional instructions on how to prepare your foundation papers and templates.

#### ► (1) NP 863

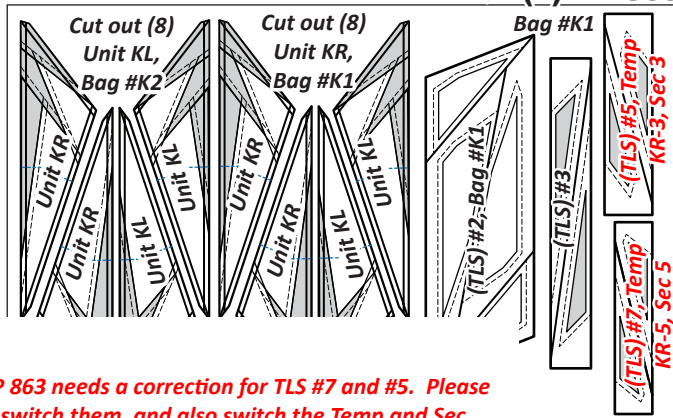

NP 863 needs a correction for TLS #7 and #5. Please switch them, and also switch the Temp and Sec names. To know if your papers are up to date, TLS #5 should be on top and TLS #7 is on the bottom. If yours aren't in this configuration, please switch

#### (1) NP 864

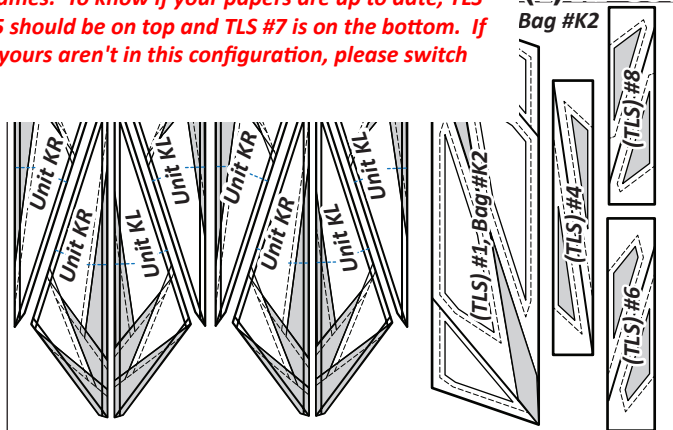

### ► Daggered Top Fabric Information:

The Unit Chart that follows includes yardage, fabric numbers, and a reference to which fabrics go with the Templates and (TLS) to complete Units KL & KR. A Color Layout, shown below, gives a visual reference to where the fabrics are located on each unit.

### ► Color Layout

**NOTE - Backside Graphic:** The color layout shown matches the printed side of the paper, and the backside of the quilt.

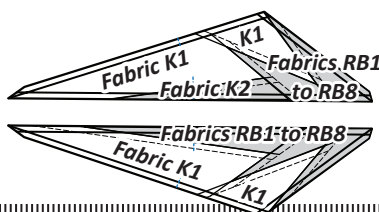

## Units KL & KR, Yardage, Make (8) ea.

GROUP K-006 FABRIC #	YARDAGE INCH	ASSIGNED COLOR	
Fabric K1 Unit KL & KR (TLS) #1 & #2	5/8 yd or (22")	Fabric Swatch	
Fabric K2 Unit KL (TLS) #4	1/8 yd or (4")	Fabric Swatch	
Fabrics RB1 to RB8 Unit KL (TLS) #3 and #5 to #8	Reference Page 6 for Yardage Information		
RB1 Fabric Swatch	RB2 Fabric Swatch	RB3 Fabric Swatch	RB4 Fabric Swatch
RB5 Fabric Swatch	RB6 Fabric Swatch	RB7 Fabric Swatch	RB8 Fabric Swatch

**NOTE - Reuse your Templates:** Templates and (TLS) are repositioned on the cut strips to achieve the number of cuts required in the cutting instructions. Please read carefully to ensure the correct number of pieces are stacked beneath each Template before cutting.

**NOTE - Repositionable Glue:** Repositionable glue placed on the backside of each template will keep the templates and (TLS) from moving during the cutting process.

### ► Fabric K1: (TLS) #1 & #2

**Step 1:** Cut and stack (4) 5-1/2" by 42" strips from Fabric K1 facing **right-side up** on your cutting table. Place **Unit KL, (TLS) #1** onto the strips aligned with the left edge of the strips. Place **Unit KR, (TLS) #2** onto the right half of the strips.

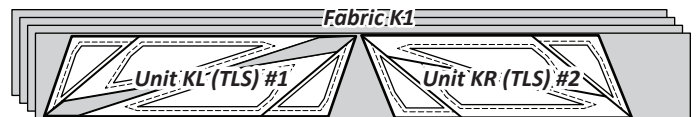

**Step 2:** Cut (4) pieces, matching the size and shape of each TLS.



**Step 3:** Four (4) fabric pieces are stacked beneath each (TLS). The cutting is completed by slicing through the paper on each Cut Line in numerical order to separate the individual sections. Clip the template pieces to the fabric beneath. Place the Unit KL pieces in Bag #K2 and Unit KR pieces in Bag #K1.



### ► Fabric K2: (TLS) #4

**Step 1:** Cut (2) 2" by 42" strips from Fabric K2. Stack the pieces facing **right-side up** on your cutting table. Place **Unit KL, (TLS) #4** on the stack and cut (4) pieces, matching the size of the Layout Sheet, repositioning the (TLS) as needed for each cut.



**Step 2:** Stack the four (4) fabric pieces beneath the (TLS), then cut on Line 1 to separate the individual sections. Clip the template pieces to the  fabric beneath. Place the pieces in Bag #K2.

► **Fabrics RB1 to RB8: (TLS) #3, #5, #6, #7, and #8**

**Step 1:** On Page 6, instructions were provided for cutting your rainbow fabrics. You should have a stack in your Group K Bag with TLS #3, and #5 to #8 attached to it. In those instructions, you already cut around the Templates. Therefore, all that is left to do is put the pieces in the correct bags, without disturbing the order. Reference the graphics below for which bags to place the pieces.

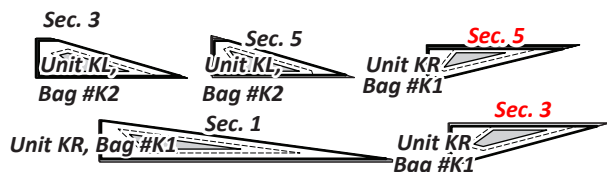

**STACKING: UNIT KL BAG #K2**

Position the templates and fabric pieces in numerical order facing *right-side up*, with the *sew-sides* aligned at the top. *Sec. 1* does not have a sew side.

**Stacking:** The stacking process begins with the largest *Sec. #* on the bottom. The pieces are stacked in reverse order finishing with *Sec. 1* on top.

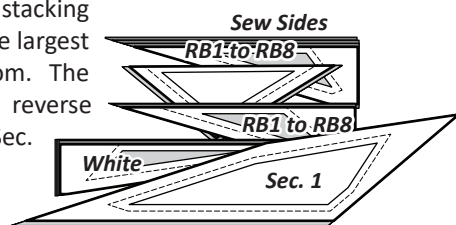

**Numbering your Papers:**

Since your units are all sewn with a different color fabric, we recommend labeling your papers as #1 to #8. This way, when you complete adding each section to the all the papers, you can put the papers back in numerical order and make sure you are sewing the correct fabric to each unit.

**FOUNDATION PAPER PIECING: UNIT KL**

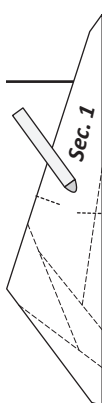

**NOTE - Tracing the Dashed Lines:** Place the foundation paper onto a light table. Flip the foundation paper over and trace the dashed lines printed on the front side of the foundation paper, onto the backside of the paper.

**Step 1:** The first piece of fabric is placed *wrong-side up* on your table. Lift the foundation paper, slide the fabric under *Sec. 1*.

1. Glue is used to adhere the fabric to the backside of the paper. Repeat **Step 1** for each foundation unit.

**Step 2:** Place the fold template over the top of *Sec. 1*, lining the edge up with the solid black line marked *Line 1*.

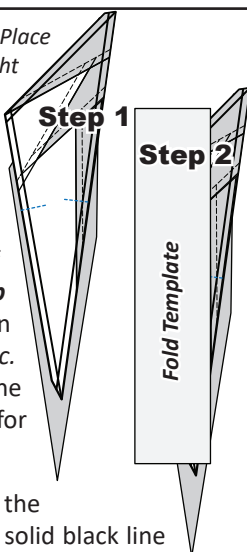

**Step 3:** Fold the paper back over the top of the fold template.

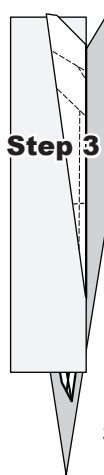

**Step 4:** Place the *Add-A-Quarter* ruler next to the folded paper and trim the fabric with your rotary cutter.



**Step 5:** Place the fabric piece for *Sec. 2 right-side up* next to the folded back paper.

**Step 6:** Lift the paper, and slide the fabric under *Sec. 1*, lining the sew side up with the trimmed seam allowance. Repeat **Steps 2-6** for each foundation paper before moving onto **Step 7**.

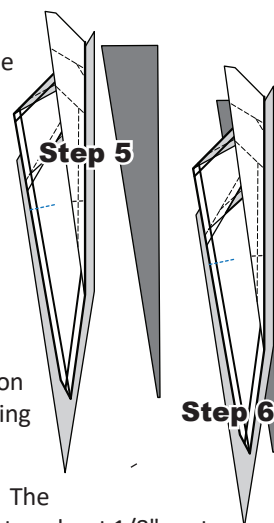

**Step 7:** Sew on *Line 1*. The stitches should start and stop about 1/8" past the beginning and the end of each stitch line. Complete the sewing on each unit before moving onto the next step.



**NOTE - Trimming the Threads:** Sewing past the ends of your sew line makes it possible to cut the thread ends off each time you trim with your *Add-A-Quarter* ruler.

**Step 8:** Loosen the glue under *Sec. 1*, then press the fabric pieces open on the backside of each paper.

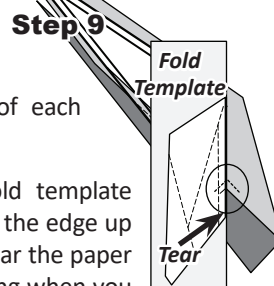

**Step 9:** Position the fold template over the top of *Sections 1 and 2*, lining the edge up with *Line 2*. Fold the paper back and tear the paper along the stitches on *Line 1*. Stop tearing when you hit the fold template.

**Step 10:** Trim the fabric with the *Add-A-Quarter* ruler.

**Step 11:** Position the third fabric piece *right-side up* next to the paper. Lift the paper and slide the fabric under *Sec. 3* in position.

