

► Wrought Iron Fence Fabric Information:

The table below includes yardage, fabric numbers, and a reference to which fabrics go with the Templates and (TLS) to complete the piecing for the Wrought Iron Fence, Group B Border. This table is your guide for not only selecting your own colors, but keeping you organized. Don't forget to cut a swatch of your chosen fabric to paste in the box in the Assigned Color column! This will help you stay organized!

Units B1 and B2, T-Templates B1-B4, Yardage		
GROUP-B FABRIC #	YARDAGE INCH	ASSIGNED COLOR
Fabric B1: Units B1R & B1L, B2R & B2L, (TLS) #1 & (TLS) #2	1-1/8 yd or (40")	Fabric Swatch
Fabric B2: Units B1R & B1L, B2R & B2L, (TLS) #3	1/2 yd or (18")	Fabric Swatch
Fabric B3: T-Temp B1R, B2R, B1L, B2L	1-1/8 yd or (38")	Fabric Swatch
Fabric B4: T-Temp B3R, B3L, B4R, B4L	1 yd or (36")	Fabric Swatch

Fabric Color Layout: The Color Layout for Group B has been provided to help you match up the fabric numbers with the assigned Units and T-Templates on the yardage charts.

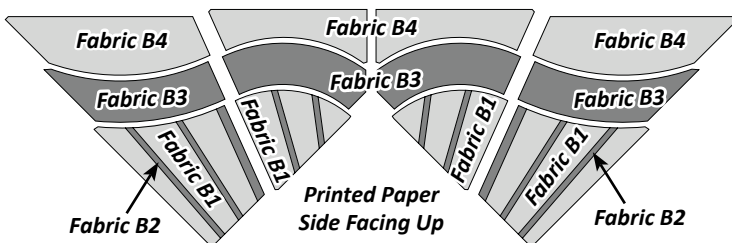

NOTE - Front and Backside fabric layout is the same for this border layout.

CUTTING INSTRUCTIONS: GROUP B

► Fabric B1: (TLS) #1 & (TLS) #2

Step 1: Cut and stack (2) 20" by 42" strips facing *right-side up* from Fabric B1.

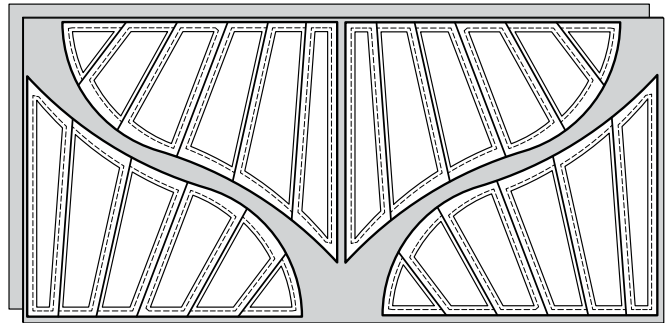

Step 2: Unit B1L & B2L TLS #2 and Unit B1R & B2R TLS #1 are used to cut (4) pieces matching the size and shape of each (TLS).

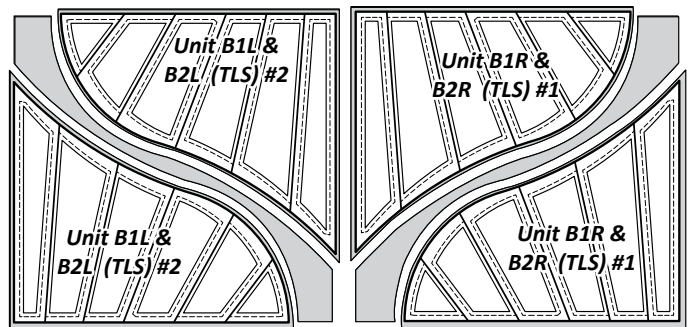

NOTE - You will need to reposition the (TLS) with each cut. Only (1) (TLS) is provided with each booklet. Repositionable Glue applied to the backside of the paper template holds the paper in position during the cutting process.

Step 3: Position (4) pieces under each (TLS) #1 & #2. Paper clip each Sec. # to the fabric beneath. Cutting is completed by slicing through the paper on each **Cut Line** in numerical order to separate the individual sections.

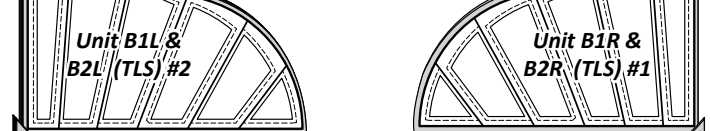

Step 4: Place the B1R & B2R pieces into Bag #B1. Place the B1L & B2L pieces into Bag #B2.

► Fabric B2: (TLS) #3

Step 1: Cut and stack (4) 4-1/2" by 42" strips facing *right-side up* from Fabric B2. Units B1R, B2R, B1L & B2L TLS #3 is used to cut (8) pieces matching the size and shape of the (TLS).

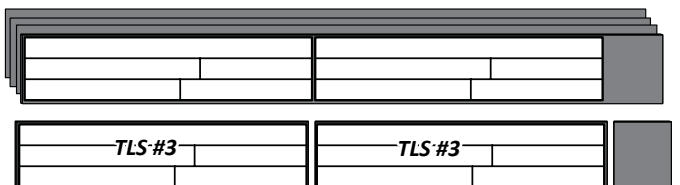

Step 2: Position (4) pieces under each (TLS). Paper clip each Sec. # to the fabric beneath. Cutting is completed by slicing through the paper on each **Cut Line** in numerical order to separate the individual sections.

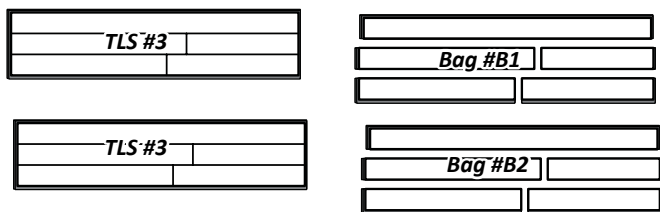

Step 3: Place one set of the strips into Bag #B1. Place the other set into Bag #B2.

► **Fabric B3: T-Temp B1L, B2L, B1R, B2R**

Step 1: Cut and stack (4) 9-1/2" by 42" strips facing **right-side up** from Fabric B3. **T-Template B1R, B2R, B1L, & B2L** are used to cut (4) pieces, matching the size and shape of each T-Template.

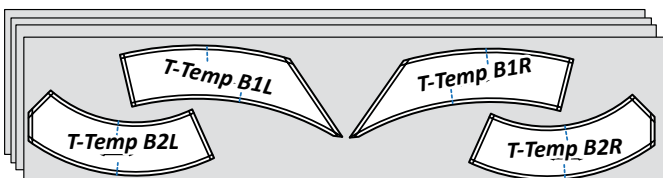

NOTE - Repositionable Glue applied to the backside of the paper template holds the paper in position during the cutting process.

Step 2: Place the BR Templates into Bag #1 and the BL Templates into Bag #B2.

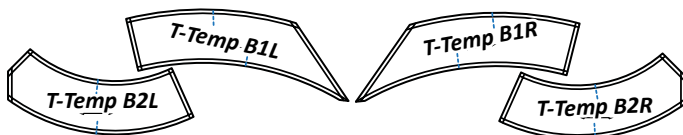

► **Fabric B4: T-Temp B3L, B4L, B3R, B4R**

Step 1: Cut and stack (4) 9" by 42" strips facing **right-side up** from Fabric B4. **T-Template B3L, B4L, B3R, & B4R** are used to cut (4) pieces, matching the size and shape of each T-Template.

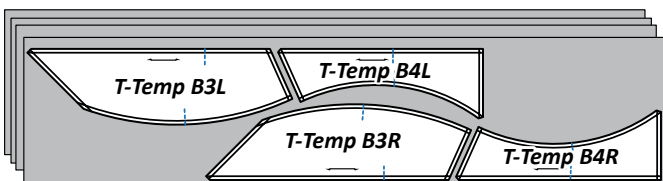

Step 2: Place the BR Templates into Bag #B1 and the BL Templates into Bag #B2.

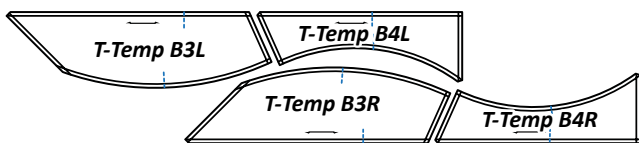

REGISTRATION LINES (TRP)

The T-Templates in Bags #B1, #B2, all have registration lines (marked as dotted lines with a TRP label). These must be transferred to your fabric pieces, one template at a time. Align the edges of the first T-Template with the fabrics beneath so all of the edges are perfectly aligned. A sample showing some of the T-Templates with the **(TRP) lines** is shown below.

Set your stitch length at 2.8 on your machine and sew the TRP Lines on each piece of fabric, using your T-Templates as a guide to mark the location either through needle-punching the entire stack at once, or using a marking pencil to mark the individual pieces. After the TRP Lines are marked on the fabrics, they can be stitched onto each of the fabric pieces.

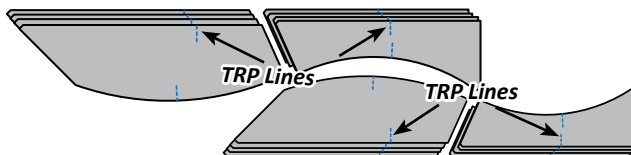

The excess threads on the front and backside of each fabric are trimmed. Clip the templates and fabric pieces back together, then place the pieces into their assigned bags. Repeat this process for all the TRP Lines printed on the T-Templates.

STACKING: UNITS B1 & B2, BAG #B1 & #B2

Organization: Stack the templates and fabric pieces in numerical order facing right-side up with the sew-side aligned at the top.

Stacking: The stacking process begins with the largest Sec. # on the bottom. The pieces are stacked in reverse order finishing with Sec. 1 on top.

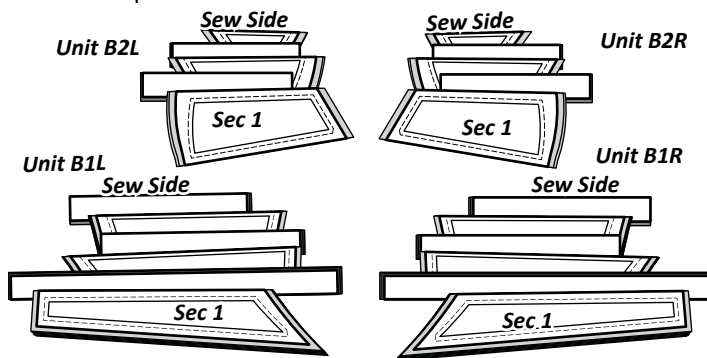

FOUNDATION PAPER PIECING: UNIT B1L

NOTE - *Tracing the Dashed Lines:* Once you are familiar with the process for Foundation Paper Piecing, tracing the backside of the foundation paper become optional.



Step 1: The first piece of fabric is placed **wrong-side up** on your table. Lift the foundation paper, slide the fabric under Sec. 1. Glue is used to adhere the fabric to the backside of the paper. Repeat Step 1 for each foundation unit.