

## SEWING ON THE VEIN, CURVED PAPER PIECING:

**Sewing the S-Curve:** The process for sewing the accent strip onto Unit A1 is completed in two parts.

**Step 16:** First, position both fabrics facing *right-sides-together*, (vein on top). Match and pin the TRP Lines on the vein up with the TRP Lines, labeled above as point A, & C. Then glue the raw edge of the accent strip along the basting stitches between points B and C, to secure the edges.

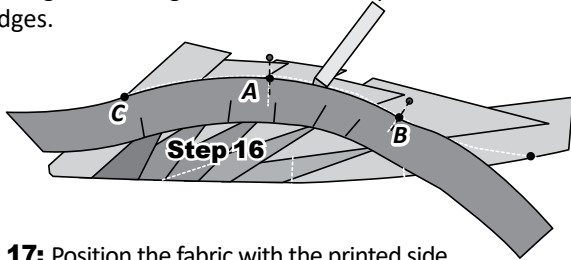

**Step 17:** Position the fabric with the printed side of the paper facing up, fabric on the bottom and sew Line 12 starting at point B and ending at point C. To avoid sewing puckers into the seam, lift the paper about 1/2" and hold it slightly above the surface of the machine as you sew on the stitch line. This allows the fabric to move freely as it passes over the feed dogs on your machine.

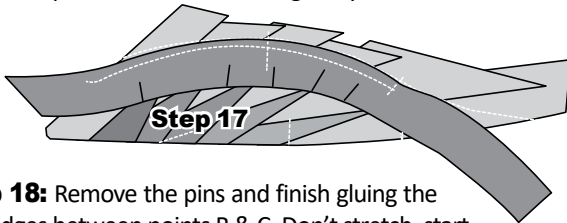

**Step 18:** Remove the pins and finish gluing the raw edges between points B & C. Don't stretch, start gluing at point D and work the fabric along the basting stitch back to point C. Note- you may need to make a few very small clips along the inside edge of the vein to get the fabric to work into place. Once the edges are secure you can complete the sewing by repeating the sewing process described in Step 16, except this time sew from point D to point B.

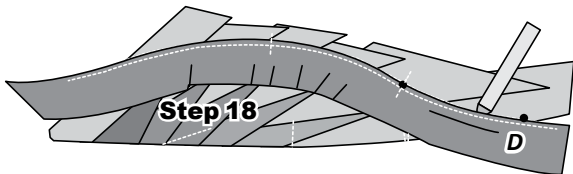

**Step 19:** After the seam is completed, fold and press the accent strip to cover the curved section on the foundation paper assigned to Sec. 12.

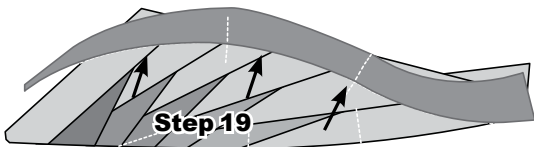

**Step 20:** The excess fabric and paper is trimmed off on the solid line along the top edge of Sec 12.

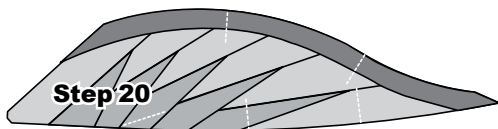

**Step 21:** The fabric, paper and basting stitches hidden under the accent strip needs to be trimmed away. Leaving this excess under the vein leaves to many layers of fabric under the vein and will show after the quilt is quilted. To remove this excess, position the paper side of Unit A1 down against the cutting table. The accent strip is temporarily folded back to gain access to the fabric and paper underneath the strip.

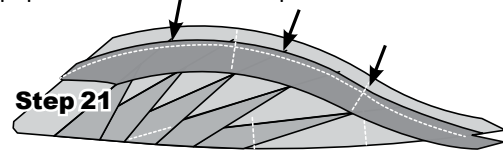

**Step 22:** Once the fabric is folded back, the excess fabric, paper, and basting threads are trimmed away, along the inside edge of the basting stitches. This will leave you with a 'scant-quarter-inch-seam' under the accent strip.

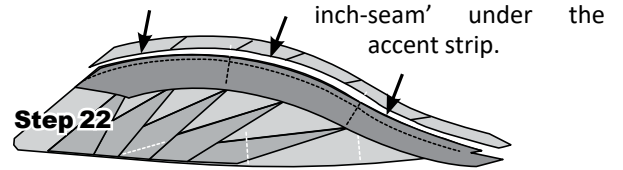

**Step 23:** Repress the accent strip facing out and place the pieces back in Bag #A1.

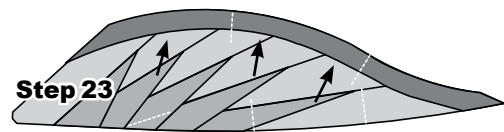

## STACKING: UNIT A2, UNIT #BAG A2

**NOTE - If you have cut from (2) or more colors, Fabric Group :a for each Fabric # will be on the top of each stack.**

**NOTE - No Paper Piecing:** If your Unit B2 was prepared for Alternate 2 or 3, then skip to Sewing on the Vein.

**Organization:** Stack the templates and fabric pieces in numerical order facing *right-side-up* with the *Sew-side* aligned at the top.

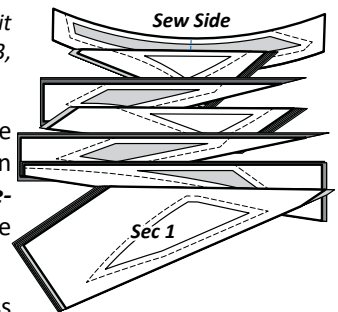

**Stacking:** The stacking process begins with the largest Sec. # on the bottom. The pieces are stacked in reverse order finishing with Sec. 1 on top.

**Labeling Your Papers:** If you are using different color options, make sure to label your papers as #1 to #8. It also might help to glue a small swatch to your sections or your papers to identify the fabrics you are sewing onto each. This will help prevent you from sewing the wrong fabric to the wrong section or paper.

## FOUNDATION PAPER PIECING: UNIT A2

*NOTE - Tracing the Dashed Lines: Optional.*

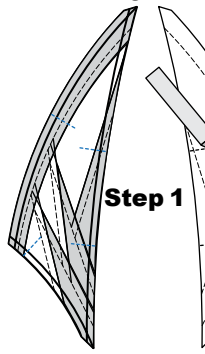

**Step 1:** Find Sec. 1 on the foundation paper. Place a small amount of fabric glue on the backside of the paper under Sec. 1.

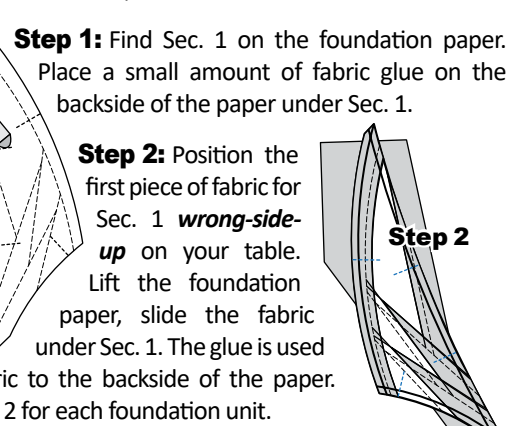

**Step 2:** Position the first piece of fabric for Sec. 1 *wrong-side-up* on your table. Lift the foundation paper, slide the fabric under Sec. 1. The glue is used to adhere the fabric to the backside of the paper. Repeat Steps 1 and 2 for each foundation unit.

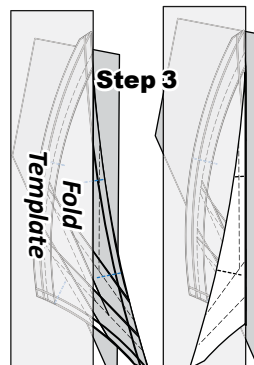

**Step 3:** Place the fold template over the top of Sec. 1. Line the edge up with the solid black line marked Line 1 and fold the paper back over the top of the fold template.

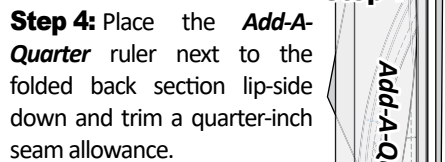

**Step 4:** Place the *Add-A-Quarter* ruler next to the folded back section lip-side down and trim a quarter-inch seam allowance.

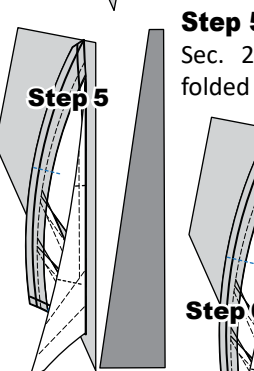

**Step 5:** Place the fabric piece for Sec. 2, *right-side up* next to the folded back paper as shown.

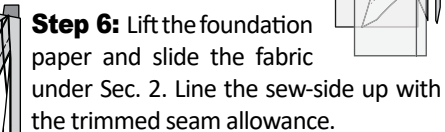

**Step 6:** Lift the foundation paper and slide the fabric under Sec. 2. Line the sew-side up with the trimmed seam allowance.

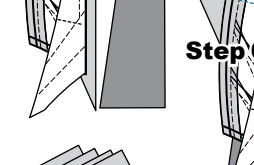

**Step 7:** Repeat *Steps 3-6* for each foundation paper before moving onto Step 8. When you have completed your stacking for the first round take your pieces to the machine and sew on Line 1.

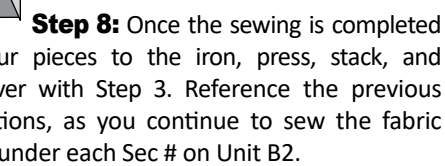

**Step 8:** Once the sewing is completed take your pieces to the iron, press, stack, and start over with Step 3. Reference the previous instructions, as you continue to sew the fabric pieces under each Sec # on Unit B2.

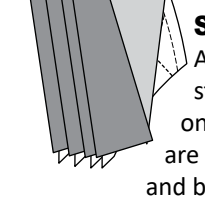

**Sewing the (TRP) and Basting Lines:** After adding the fabric for Sec. 6 re-set your stitch length at 2.5 and sew the (4), (TRP) Lines on each Foundation Unit. After the (TRP) Lines are sewn, the threads are trimmed on the front and backside of each unit.

**Step 9:** A basting stitch is then sewn the full length of the dashed line labeled Basting Stitch Line 6. Keep your stitch length set at 2.5 for the basting stitch.

**Step 10:** Trim the excess paper off along the bottom edge and up the side. Do not trim the top edge along Sec 7.

## SEWING ON THE VEIN:

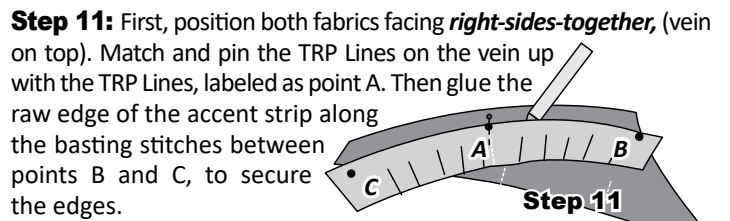

**Step 11:** First, position both fabrics facing *right-sides-together*, (vein on top). Match and pin the TRP Lines on the vein up with the TRP Lines, labeled as point A. Then glue the raw edge of the accent strip along the basting stitches between points B and C, to secure the edges.

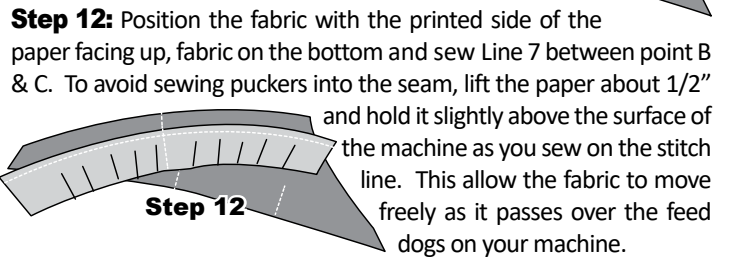

**Step 12:** Position the fabric with the printed side of the paper facing up, fabric on the bottom and sew Line 7 between point B & C. To avoid sewing puckers into the seam, lift the paper about 1/2" and hold it slightly above the surface of the machine as you sew on the stitch line. This allow the fabric to move freely as it passes over the feed dogs on your machine.

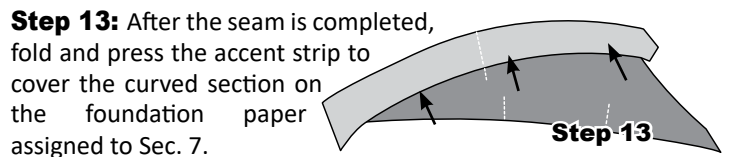

**Step 13:** After the seam is completed, fold and press the accent strip to cover the curved section on the foundation paper assigned to Sec. 7.

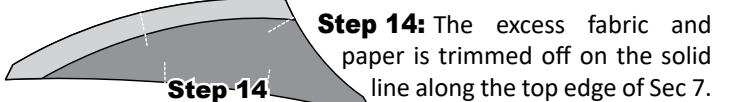

**Step 14:** The excess fabric and paper is trimmed off on the solid line along the top edge of Sec 7.

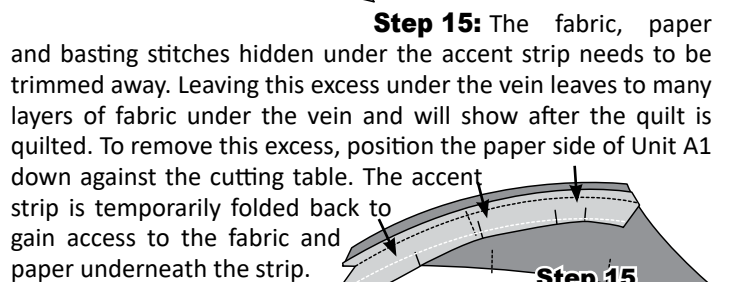

**Step 15:** The fabric, paper and basting stitches hidden under the accent strip needs to be trimmed away. Leaving this excess under the vein leaves to many layers of fabric under the vein and will show after the quilt is quilted. To remove this excess, position the paper side of Unit A1 down against the cutting table. The accent strip is temporarily folded back to gain access to the fabric and paper underneath the strip.

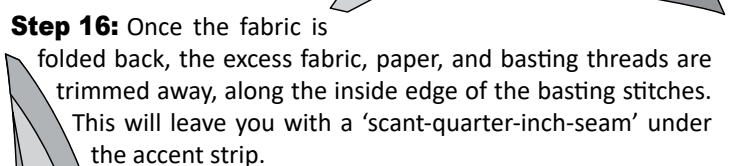

**Step 16:** Once the fabric is folded back, the excess fabric, paper, and basting threads are trimmed away, along the inside edge of the basting stitches. This will leave you with a 'scant-quarter-inch-seam' under the accent strip.

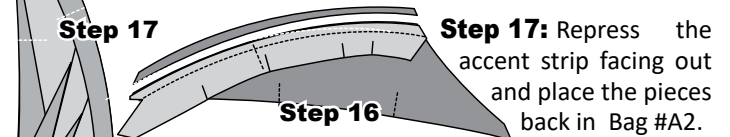

**Step 17:** Repress the accent strip facing out and place the pieces back in Bag #A2.

## BLOCK ASSEMBLY INSTRUCTIONS

**Removing Paper:** It is recommended that you only remove the foundation paper from each unit just prior to joining it to another block or block group. Some of the units do not require you to remove the paper until you are ready to assembly the whole quilt, while other papers are removed so you can joined pieces within a block group or complete curved piecing if required. The unit papers for Group A are complete and therefore should be placed back into their assigned Bag # until you are ready to assembly your Quilt. If this is the last block group needed to finish the quilt, then it's time to return to the Introduction Booklet and follow the Assembly Instructions.