

Units AE1 & AE2 Yardage, Make (8) each

GROUP-AE FABRIC #	YARDAGE INCH	ASSIGNED COLOR
Fabric AE1 Unit AE1/AE2 (TLS) #1	1 yd or (35")	Fabric Swatch
Fabric AE2: Unit AE1/AE2 (TLS) #2	5/8 yd or (22")	Fabric Swatch
Fabric AE3:a: Unit AE2 (Temp AE2-8)	1/4 yd or (9")	Fabric Swatch
Fabric AE3:b: Unit AE2 (Temp AE2-8)	1/4 yd or (9")	Fabric Swatch

► Color Layout & Fabric Information:

The table that follows includes yardage, fabric numbers, and a reference to which fabrics go with the Templates and (TLS) to complete the units in this group. This table is your guide for not only selecting your own colors, but keeping you organized. Don't forget to cut a swatch of your chosen fabric to paste in the box in the Assigned Colors column!

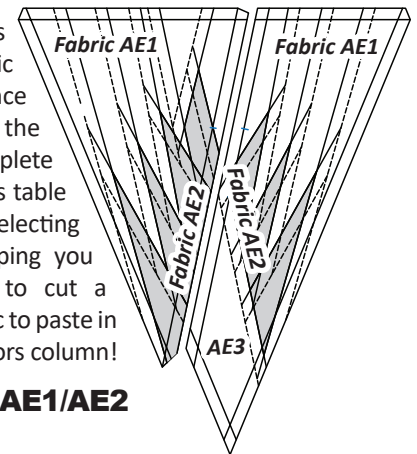

► Fabric AE1: Unit AE1/AE2 (TLS) #1

Step 1: Cut and stack (4) 8-3/4" by 42" strips facing *right-side up*.

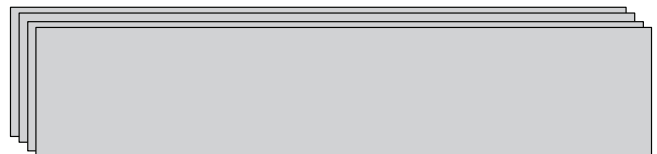

Step 2: The *Unit AE1 & AE2 Template Layout Sheet #1* is placed onto the strips as shown. Cut (8) pieces, matching the size and shape of the Template Layout Sheet.



Step 3: The (8) pieces are stacked under the (TLS). A paper clip is used to clip each section to the fabric to keep the template pieces from moving in the cutting process. The cutting is completed by slicing through the paper on each cut line to separate the individual sections.



Step 4: Place the individual template pieces labeled [AE1-1, AE1-3, AE1-4, AE1-6, AE1-8, and AE1-10] that are clipped to the fabric with the *Unit AE1 Foundation Papers* in Bag #AE1. Place the individual template pieces labeled [AE2-1, AE2-3, AE2-5, and AE2-

► Fabric Reference Information

The Ice Crystal Star Layout fits many of Quiltworx designs, including many of the Cattail Mixers and soon a series of Diamond Layouts including Prismatic Star, Fractured Star, and Diamonds in Bloom. In many of our patterns, the star unit can only be used in one Group. However, in several of our future publications you will see the star units being used in more than one group in the same pattern, resulting in many sizes and variations of the DIA Mixer Units.

If you have chosen this block as a mixer to use in a different location other than Group A you need to be careful when it comes to fabric reference numbers because you may have two blocks that use the same Fabric Reference #s. If this is the case this can be handled by labeling the Fabrics with the Group Letter Identifier first. For example, when using this block in Group B, or C, simply add the Group letter in front of the fabric reference #s. Example: Group B: AE-S1 to Group B: AE-S18 or Group C: AE-S1 to Group C: AE-S18. The lone star block in Group A would then be noted as AE-S1 to AE-S18. Since we do not know, in your mixer, where you have chosen to use your blocks, we cannot put these identifiers in for you. It will be up to you to keep the groups separate which is very easy if you simply work on only completing one Group at a time. Just be aware of this as you work on your pattern to minimize confusion!

We have named all of the matching diamond with an identifier like AA to AZ so if you put more than one block in a quilt, it will be easier to keep them organized. This is the AE block.

7], which are clipped to the fabric with the *Unit AE2 Foundation Papers* in Bag #AE2.

► **Fabric AE2: Unit AE1/AE2 (TLS) #2**

Step 1: Cut and stack (2) 11" by 42" strips facing *right-side up*.



Step 2: The *Unit AE1 & AE2 Template Layout Sheet #2* is placed onto the strips as shown. Cut (4) pieces, matching the size and shape of the Template Layout Sheet.

Step 3: The (4) pieces are stacked under the (TLS). A paper clip is used to clip each section template to the fabric beneath to keep the template pieces from moving in the cutting process. The cutting is completed by slicing through the paper on each cut line to separate the individual sections.



Step 4: Place the individual template pieces labeled for Unit AE1 with the *Unit AE1 Foundation Papers* in Bag #AE1. Place the individual template pieces labeled for Unit AE2 with the *Unit AE2 Foundation Papers* in Bag #AE2.

► **Fabric AE3:a & AE2:b: Unit AE2 Temp AE2-8**

Step 1: Cut and place (1) 9" by 42" strip from each fabric facing *right-side up*.

Step 2: The *Unit AE2 Temp AE2-8* is used to cut (8) pieces total, (4) from each strip, measuring the same size as the layout sheet from each color. The template pieces are placed in Bag #AE2.

NOTE - Making them the same Color: If you have made these all the same color, then you only need (1) 9" x 42" strip and all (8) pieces can be cut from (1) strip.

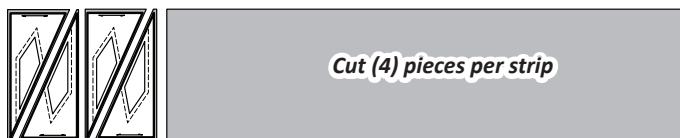

■ **STACKING: UNIT AE1 BAG #AE1**

The template pieces are stacked in the order you will sew them to the foundation paper. Position the templates and fabric pieces in numerical order facing *right-side up*, with the *sew-sides* aligned at the top. Sec. 1 does not have a sew side.

Stacking: The stacking process begins with the largest Sec. # on the bottom. The pieces are stacked in reverse order finishing with Sec. 1 on top.

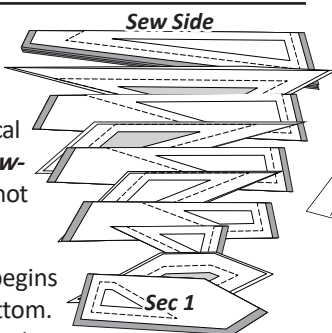

■ **FOUNDATION PAPER PIECING: UNIT AE1**

NOTE - Tracing the Dashed Lines: Place the foundation paper onto a light table. Flip the foundation paper over and trace the dashed lines printed on the front side of the foundation paper, onto the backside of the paper.

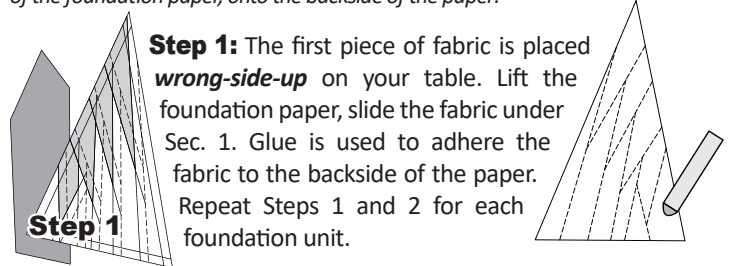

Step 1: The first piece of fabric is placed *wrong-side-up* on your table. Lift the foundation paper, slide the fabric under Sec. 1. Glue is used to adhere the fabric to the backside of the paper. Repeat Steps 1 and 2 for each foundation unit.

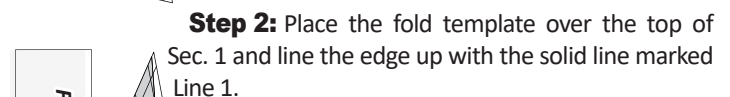

Step 2: Place the fold template over the top of Sec. 1 and line the edge up with the solid line marked Line 1.



Step 3: Fold the paper back over the top of the fold template.



Step 4: Place the *Add-A-Quarter* ruler next to the folded paper and trim the fabric with your rotary cutter.



Step 5: Place the fabric piece for Sec. 2, *right-side up* next to the folded back paper.

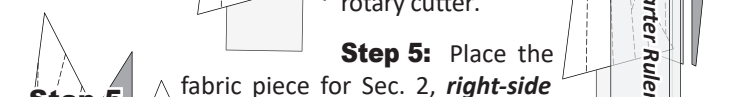

Step 6: Lift the paper, and slide the fabric under Sec. 1, line the sew-side up with the trimmed seam allowance. Repeat *Steps 1-6* for each foundation paper before moving onto Step 7.

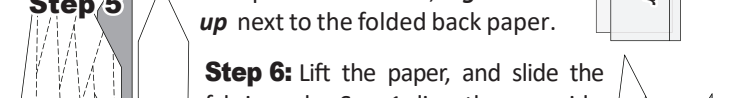

Step 7: Sew on Line 1. The stitches should start and stop about 1/8" past the beginning and the end of each stitch line. Complete the sewing on each Unit before moving onto the next step.

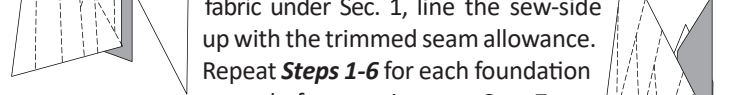

NOTE - Trimming the Threads: Sewing past the ends of your sew line makes it possible to cut the thread ends off each time you trim with your *Add-A-Quarter* ruler.

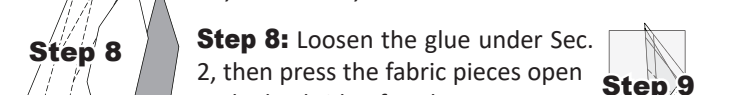

Step 8: Loosen the glue under Sec. 2, then press the fabric pieces open on the backside of each paper.

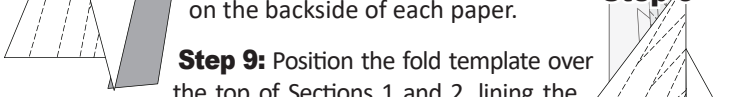

Step 9: Position the fold template over the top of Sections 1 and 2, lining the edge up with Line 2. Fold the paper back and tear the paper along the stitches on Line 1. Stop tearing when you hit the fold template.

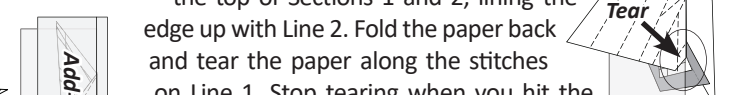

Step 10: Trim the fabric with the *Add-A-Quarter* ruler. Position the third fabric piece *right-side up* next to the paper. Lift the paper and slide the fabric under Sec. 3 in position.