

Step 11: Position the fold template over the top of Sections 1 and 2, lining the edge up with Line 2. Fold the paper back and tear the paper along the stitches on Line 1. Stop tearing when you hit the fold template.

Step 12: Use the *Add-A-Quarter* ruler to trim the excess fabric, then place the 3rd fabric next to the foundation paper. Lift the foundation unit on top, lining up the sew-side with the trimmed seam allowance.

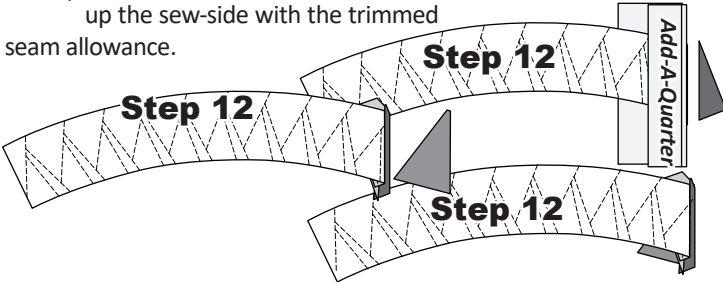

Step 13: Take the pieces to your machine, sew on Line 2, open and press.

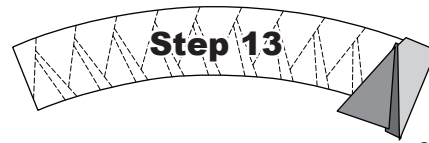

Repeat the Previous Steps:

Repeat the process for each section. When the

paper piecing is complete you will need to complete the sewing on the registration lines. After sewing the (TRP).... Lines, trim off the excess paper and fabric on the dark solid line around the perimeter of the printed paper. The paper is not removed at this time. Place all of the B Units back into Bag # Sunrise B1.

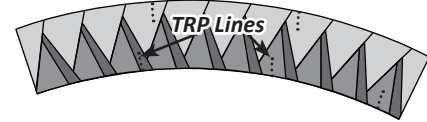

Assembly of the Sunrise Group B Units: Sunrise Group B is not assembled at this time. Assembly will happen after you finish the piecing for all units in this project.

Sunrise Mixer

RADIANT BORDER INSTRUCTIONS

► Preparing the Foundation Papers:

Step 1: Cut out (4) each of Units C1L, C1R, C2L, and C2R, from [NP 492, 493, 494] and the associated Template Layout Sheets (TLS) from [TP 306, 307 & 352], placing these in the appropriate bag. *Refer back to General Information Booklet for Foundation papers and templates for additional instructions on how to prepare your foundation papers and templates.

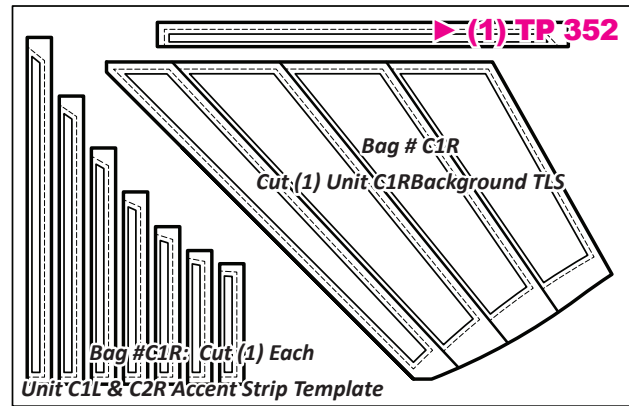
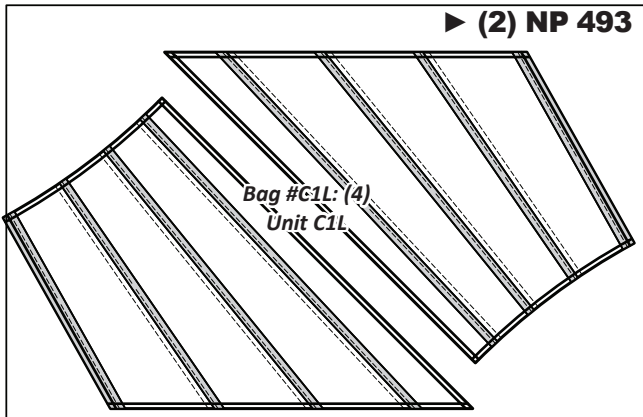
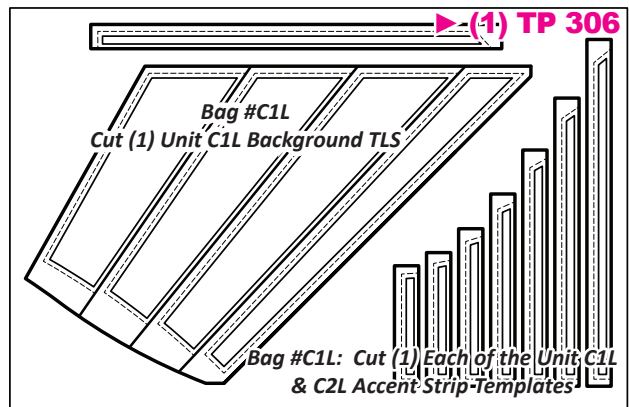
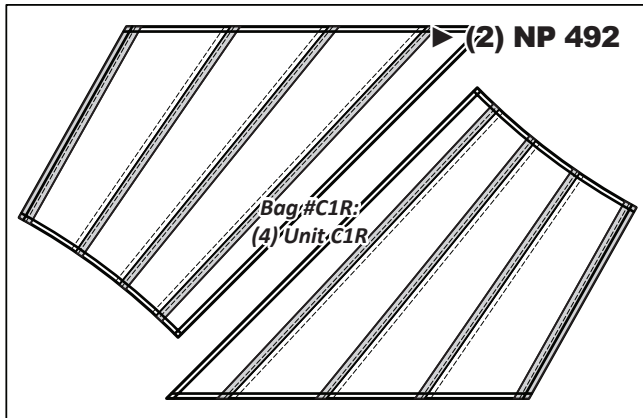
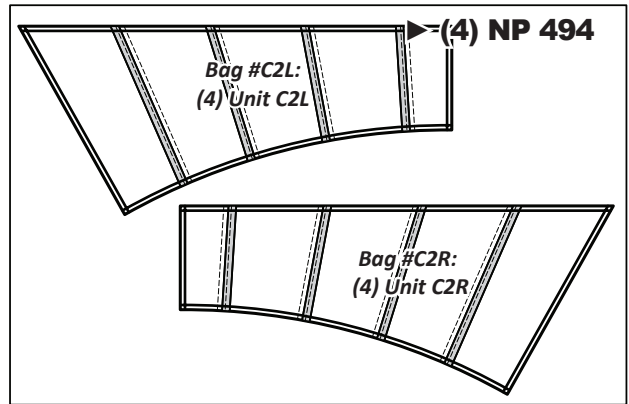

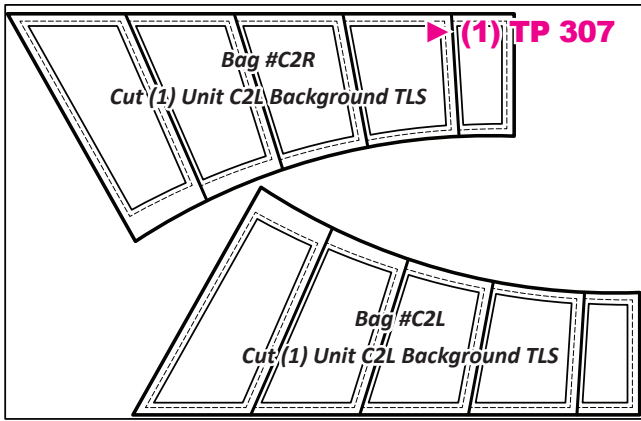

SUNRISE RADIANT BORDER: UNITS C1L, C2L, C1R, C2R, CUTTING INSTRUCTIONS, BAGS C1L, C2L, C1R, C2R.

Fabric C1, Units C1L & C1R

Step 1: From Fabric C1, cut (4) 17" x 42" Strips. Stack the strips *right-side-up* into (2) stacks. Use the *Unit C1L Background TLS* to sub-cut (4) fabric pieces the size of the Template Layout Sheet from (2) of the strips.

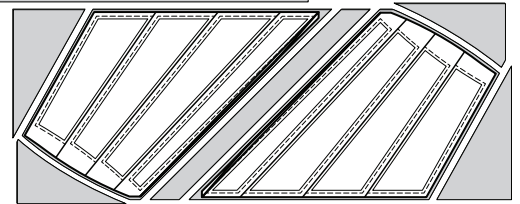
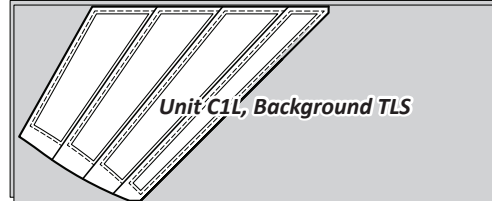

Step 2: Re-stack the pieces with their respective TLS on top. Then slice through the paper and fabric on each cut lines, in numerical order, to cut the pieces apart. Clip each stack together. Place the pieces for C1L into Bag #C1L.

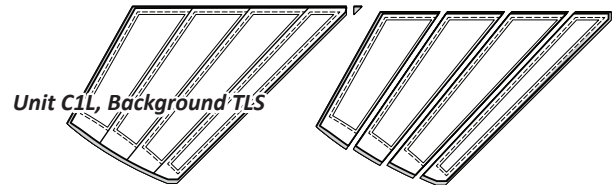

Step 3: Use the *Unit C1R Background TLS* to sub-cut (4) fabric pieces the size of the Template Layout Sheet from the other (2) strips.

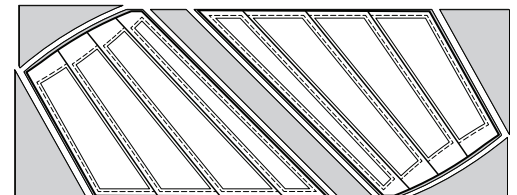
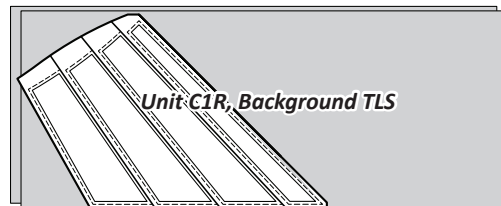

Step 4: Re-stack the pieces with their respective TLS on top. Then slice through the paper and fabric on each cut lines, in numerical order, to cut the pieces apart. Clip each stack together. Place the pieces for C1R into Bag #C1R.

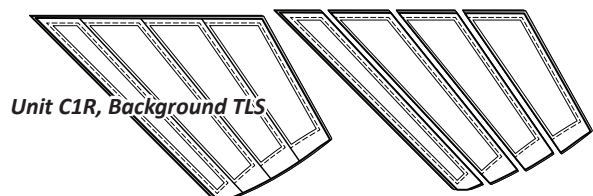

Sunrise Radiant Border Fabric Information:

The table below includes yardage, fabric references, and which fabrics should go with which cutting templates to complete Group C. This table is your guide for keeping you organized. Don't forget to cut a swatch of your chosen fabric to paste in the box in the Assigned Colors column!

Sunrise Mixer Group C: Units C1L, C1R, C2L, & C2R, Make (4) of each		
GROUP-C FABRIC #	YARDAGE INCH	ASSIGNED COLOR
Background C1 <u>C1L/C1R/C2L/C2R</u> Background TLS	<u>3-1/2 yd</u> or 124"	FABRIC SWATCH
Accent C2 <u>C1L/C1R/C2L/</u> <u>C2R Accent TLS</u>	<u>1-1/8 yd</u> or 36"	FABRIC SWATCH

