

Bali Fever

© Copyright June 2011

Designers: Bradley and Judy Niemeyer

Graphics: Carolyn Kreps, Sarah Brown, Bradley Niemeyer

Cover Sheet Samples: Judy Niemeyer, Cindi McCracken, Carolyn Kreps

Quilting by Judy Niemeyer Quilting

Bali Fever Process: Fabric strips are sewn onto the backside of each Template Sheet to build a strata of color. The foundation units are also printed on the Template Sheets. When the paper piecing is completed for each strata, the units are cut out leaving you with a finish piece. No fussy cutting with templates!

General Information

Judy and Bradley Niemeyer designed the foundation papers and the foundation strip piecing technique used to make the Bali Fever. This techniques was designed to use 2-1/2" by 42" fabric strips, such as those pre-packaged by Hoffman California Fabrics that we all know as Bali Pops™.

Foundation Papers: The foundation papers are printed on newsprint. Newsprint is lightweight and tears away from your stitches without damaging the threads. This pattern includes the following pages of foundation paper, which is enough paper to complete (1) 65" by 78" quilt as shown on the cover.

NP-145	Template Page 1	7 Pages
NP-146	Template Page 2	2 Pages
NP-148	Template Page 3	2 Page
NP-147	Template Page 4	2 Page
NP-61	Unit-S	2 Page

Instructions: Paper piecing, curved piecing and traditional piecing techniques are required to assemble this quilt. These instructions teach a quick and easy strip piecing process for foundation paper piecing using 2-1/2" strips.

Corrections: If we find that corrections are needed for this pattern after publication, they will be listed on my web page under the 'Corrections' button. You may want to check it out before you start your quilt at www.quiltworx.com.

Fabric Selection

Fabric Strips: Four (4) packages of Bali Pops™ were used to make each quilt shown on the cover. Each pkg includes (40) strips. The fabric strips are divided into (2) groups. The lighter fabrics are placed into Group #1 and the darker fabrics are placed into Group #2. An even number of fabrics in each group *is not required*. The fabric strips in each group are sorted into single color families. Then the fabric strips are stacked in order from the lightest to the darkest value.

The first question you are going to ask is; How many actual strips are required to make this quilt? The magic number is (140).

The second question you are going to ask is; Which strips do I use? I can't tell you what strips to use. I can only tell you that the strips that are left in the box, after you finish selecting your strip sets are the ones that you don't use.

Don't worry about the color! These instructions will guide you through the selection process. This will be fun!

Additional Fabrics: Additional fabric is needed to complete the S-Units, the piping, the inner border and the binding. *Refer to the yardage on the back page for the additional yardage.

General Supply List: Steam iron, ironing board, medium size cutting board, 6" by 24" ruler, small scissors, rotary cutter, seam ripper, template plastic, and a sewing machine with a quarter-inch foot.

Paper Piecing Supply List: 12" and 18" Add-A-Quarter rulers, Scotch tape, fabric glue pen, fabric glue stic, flower pins, stapler, Purple Thang, Microtex Sharps (size 70 sewing needles), and a high-quality sewing thread. Other handy tools used to keep your templates and fabrics organized are small, binder clips and large paper clips.

Definition of Common Terms and Tools

Purple Thang: A small plastic tool used like a stiletto that does not poke through the fabric. The Purple Thang is used to help work the fabric between the presser foot and feed dogs when sewing over several seams.

Add-A-Quarter Ruler: A small ruler with a quarter-inch lip on the bottom side used to trim the quarter-inch seams for foundation paper piecing. These can be purchased in three (3) sizes: 6", 12", or 18" rulers. I recommend the 12" & 18" rulers for this pattern. The 12" ruler is used to piece the S-Units, The 18" ruler is used when piecing the strips.

Washout Fabric Glue Stic: I use a water soluble fabric glue stic (Uhu is a good brand name) to adhere the first piece of fabric to the *backside* of the foundation paper.

Washout Fabric Glue Pen: I use a water soluble fabric glue pen to hold and shape the raw edges of the fabric together before sewing my curved seams.

Flower Pins: Flower pins are a long pin with a flat flower glued to the end of each pin. The flower is flat so the paper can easily be folded back over the pin and still lay flat.

Fold Template: A flat piece of template plastic used as a straight edge while folding back the foundation papers just before trimming with the Add-A-Quarter ruler. A 3" by 12" piece of template plastic should be cut to use with the 12" Add-A-Quarter. A 3-1/2" by 18" piece is cut for the 18" ruler.

Sewing Lines on the Foundation Papers: The sewing lines on the foundation papers are the dark solid lines separating each section. The lines are marked in chronological order starting with Line 1, 2, 3 and etc.

Dashed Lines: These lines are reference lines marking the edge of your 1/4" seam allowance. *Do not sew on these lines.* The dashed lines are used to help you locate the actual shape and size of each section on the *backside* of the paper.

Sewing Fabric Pieces, on the Foundation Paper:

When sewing the fabrics to the foundation paper, each fabric piece must cover the underside area plus the extended seam allowance for each section you are sewing. The dashed lines can be used to locate this area before adding your fabrics. This can be done three different ways and each technique works.

1. I fold and crease the papers on the dashed line before I add the next piece of fabric. After creasing the dashed lines, I flip the paper over to find each section on the backside of the paper.

2. You can also trace the dashed lines on the backside of the foundation paper. This can be done by using a light-table or by placing the paper up to a window. Tracing works best when you are working on large foundation units.

3. Some people hold the paper up to a light-source to see if the fabric has been properly placed under the section they are sewing.

Templates

Paper Piecing Template are oversized templates, with extra seam allowances designed for each section on the foundation paper. The extra room is needed when you position the fabric under the foundation paper. After the fabric is sewn onto the foundation paper, the excess fabric is trimmed away using your Add-A-Quarter ruler. You will find the templates printed on the news print along with the foundation papers.

Template Layout Sheets

Template Layout Sheets: A Template Layout Sheet is made by grouping together several paper piecing templates to be cut at one time. The templates are arranged to fit on one large sheet of paper to utilize grain line, save fabric and speed up the cutting process.

Template layout sheets are used to cut out the individual fabric pieces for each section on any given foundation unit. The template layout sheets are positioned onto a stack of fabric. Then your rotary cutter is used to slice through the paper and fabric, allowing several layers of fabric to be cut at one time. Again you will find the template layout sheets printed on the news print with the foundation papers.

Setting up your Bags #1-4:

The foundation papers, templates and template layout sheets are divided into (4) bags. Sort through the foundation papers and place them into the appropriate Bag # listed below.

NP -145, Template Sheet #1, these are place into Bag #1.

NP-146, Template Sheet #2, these are place into Bag #2.

NP-148, Template Sheet #3, these are place into Bag #3.

NP-147, Template Sheet #4, these are place into Bag #4.

NP 61, Unit-S, these are placed into Bag #2 along with NP-146.

Foundation Papers.

Templates and Template Layout Sheets

Foundation Papers: The foundation papers are cut out by trimming the excess paper away, approximately 1/8" beyond the outside cutting line. Trimming off the excess paper will make it easier to position and sew the fabric strips under the paper. The foundation papers for the strip piecing are labeled as Template Sheet 1, 2, 3, and 4. The foundation papers for the spike units are labeled Unit S.

Templates: The templates and template layout sheets are cut on the solid line that forms a boundary.

Bag #1: Template Sheet 1,

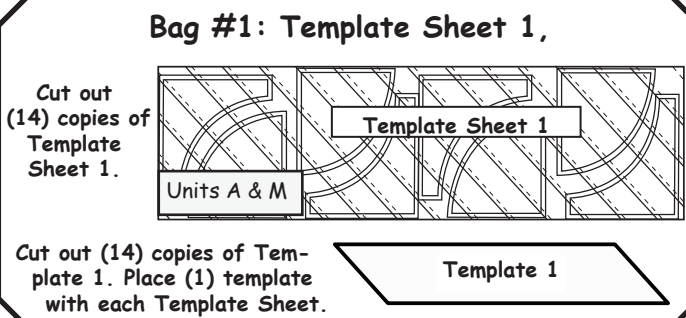

Cut out (14) copies of Template Sheet 1.

Cut out (14) copies of Template 1. Place (1) template with each Template Sheet.

Bag #2: Template Sheet 2, & Unit-S

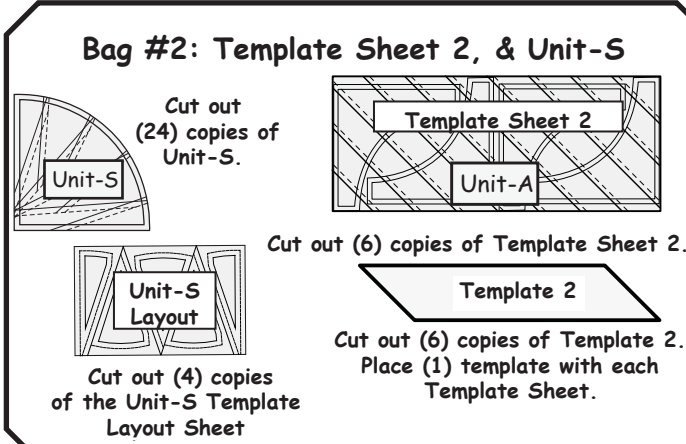

Cut out (24) copies of Unit-S.

Cut out (6) copies of Template Sheet 2.

Cut out (6) copies of Template 2. Place (1) template with each Template Sheet.

Cut out (4) copies of the Unit-S Template Layout Sheet.

Bag #3: Template Sheet 3,

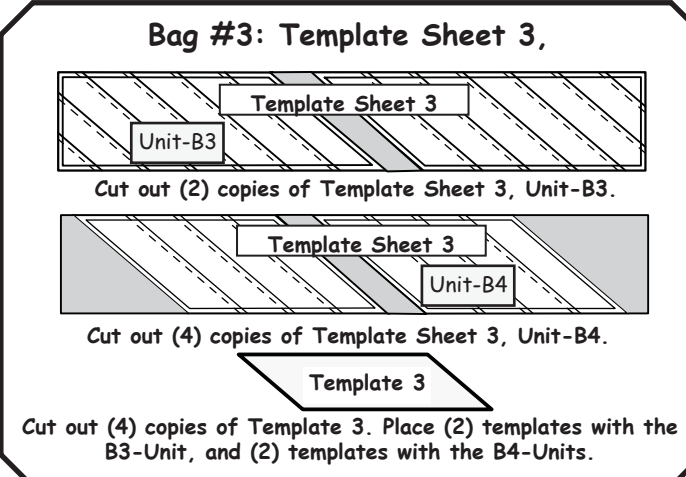

Cut out (2) copies of Template Sheet 3, Unit-B3.

Cut out (4) copies of Template Sheet 3, Unit-B4.

Cut out (4) copies of Template 3. Place (2) templates with the B3-Unit, and (2) templates with the B4-Units.

Bag #4: Template Sheet 4,

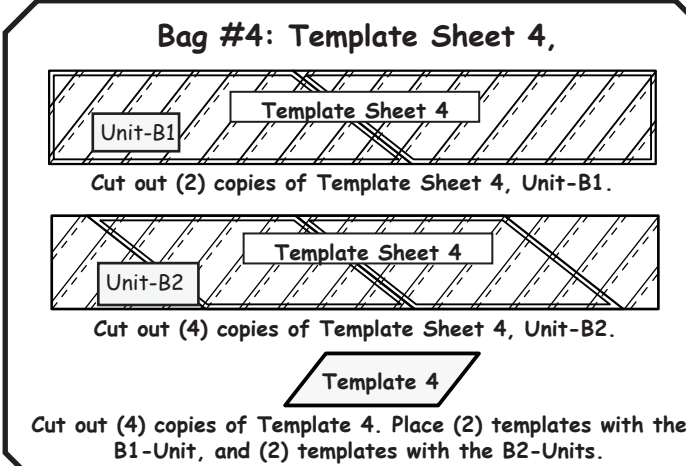

Cut out (2) copies of Template Sheet 4, Unit-B1.

Cut out (4) copies of Template Sheet 4, Unit-B2.

Cut out (4) copies of Template 4. Place (2) templates with the B1-Unit, and (2) templates with the B2-Units.

Foundation Paper Piecing, Unit-S (24)

Step 1: Place a small amount of fabric glue on the *backside* of the foundation paper under Sec. 1.

Step 2: Position the first piece of fabric *wrong-side-up* on your table. Lift the foundation paper and slide the first piece under Sec. 1. The *wrong-side* of the fabric is glued to the backside of the paper.

Step 3: Place the fold template over the top of Sec. 1, lining the edge up to Line 1. Fold the paper back over the fold template.

Step 4: Place the Add-A-Quarter ruler next to the folded edge on the paper, lip-side down, and trim a quarter-inch seam.

Step 5: Place the second piece of fabric for Sec. 2 *right-side-up* next to the folded back paper as shown.

Step 6: Lift the foundation paper and slide the second fabric piece under Sec. 2. Line the edge of the second fabric up with the trimmed quarter-inch seam.

Step 7: Lift both pieces to your machine with the paper. Open the paper and sew on Line 1. Start at the top of Line 1 and sew to the bottom of Line 1 just off the paper.

Step 8: Loosen the glue under Sec. 1, then flip the paper over and press the fabric pieces to the open position.

Step 9: Place the fold template over the top of Sec. 1, & 2 lining up the edge on Line 2.

Step 10: Tear the paper on the stitch line, back to the fold template. This allows the fabric to lay flat, making it easier to trim with the *Add-A-Quarter* ruler.

Step 11: Place the Add-A-Quarter ruler next to the folded edge on the paper, lip-side down, and trim a quarter-inch seam.

Step 12: Place the third piece *right-side-up* next to the folded back paper as shown.

Step 13: Lift the foundation paper and slide the fabric under Sec. 3.

Step 14: Open the paper and sew on Line 2. When you are finished sewing, press the fabric open.

Step 15: Continue adding the pieces for each section. When the foundation piecing is finished, trim off the excess fabric and foundation paper

Note: Do not remove the foundation paper.

Bag #2. Preparing your Fabric Strips

In Bag #2 you should have (6) Template Sheets, (6) Strip Sets with three strips in each set, and several template pieces.

1. Open and stack your first set of strips *right-side-up*. Line up the edges as best as you can.

Stack (3) Strips

2. Position (3) templates facing *right-side-up* onto your strips.

Template 2 Template 2 Template 2

3. Crosscut the strips into (3) sections.

4. Cut (2) triangles off the ends of two pieces. The triangles are for (Sec. 1 & Sec. 11).

5. Arrange your strips facing *right-side-up* in the order you want them sewn onto the foundation paper.

6. Repeat the cutting process for the remaining (5) sets.

Foundation Paper Piecing, Template Page 1, Unit-A

OK, you know how it works!

Step 1: Glue the first piece under Sec. 1

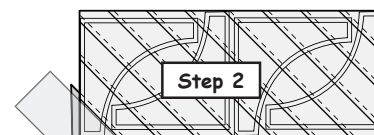
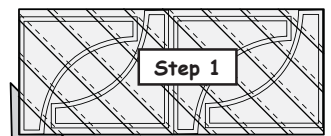

Step 2: Line the edge of the fold template up with Line 1

Foundation Paper Piecing, Border Units B3, B4, B1, B2,

Note: Always pre arrange the fabric strips onto your foundation papers before you begin the paper piecing. It is easier to change out a fabric strip before you sew it onto the paper that after.

Bag #3: Unit-B3

Unit-B3: You should have (2) Template Sheets and (1) Strip Set, with six fabric strips.

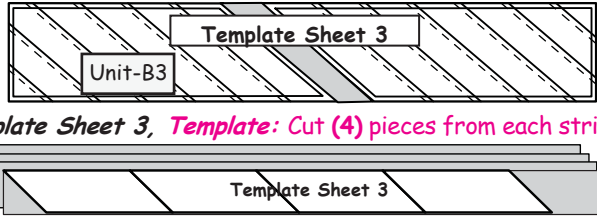

Template Sheet 3, Template: Cut (4) pieces from each strip.

Arrange the fabric pieces for each Template Sheet in the order in which they are sewn onto the foundation papers. Complete the paper piecing and trim the excess fabric and paper off around each unit. Complete each set.

Bag #3: Unit-B4

Unit-B4: You should have (4) Template Sheets and (1) Strip Set, with eight fabric strips.

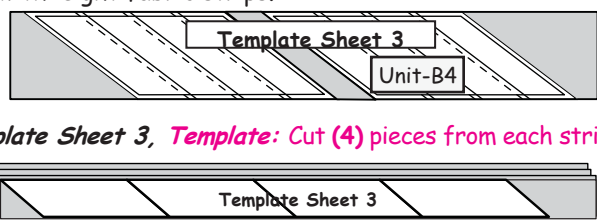

Template Sheet 3, Template: Cut (4) pieces from each strip.

Complete the paper piecing for each strip, trim the foundation papers.

Bag #4: Unit-B2

Unit-B2: You should have (4) Template Sheets and (1) Strip Set, with eight fabric strips.

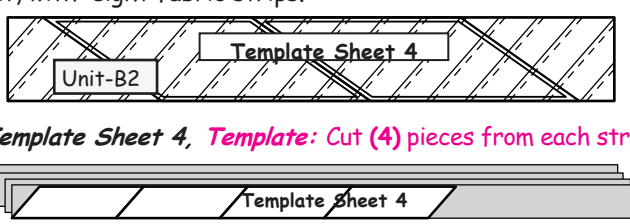

Template Sheet 4, Template: Cut (4) pieces from each strip.

Complete the paper piecing for each strip, trim the foundation papers.

Bag #4: Unit-B1

Unit-B1: You should have (2) Template Sheets and (1) Strip Set, with sixteen fabric strips.

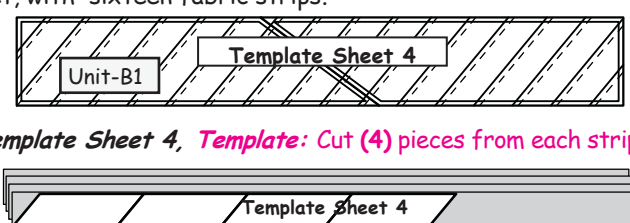

Template Sheet 4, Template: Cut (4) pieces from each strip.

Complete the paper piecing and trim the foundation papers.

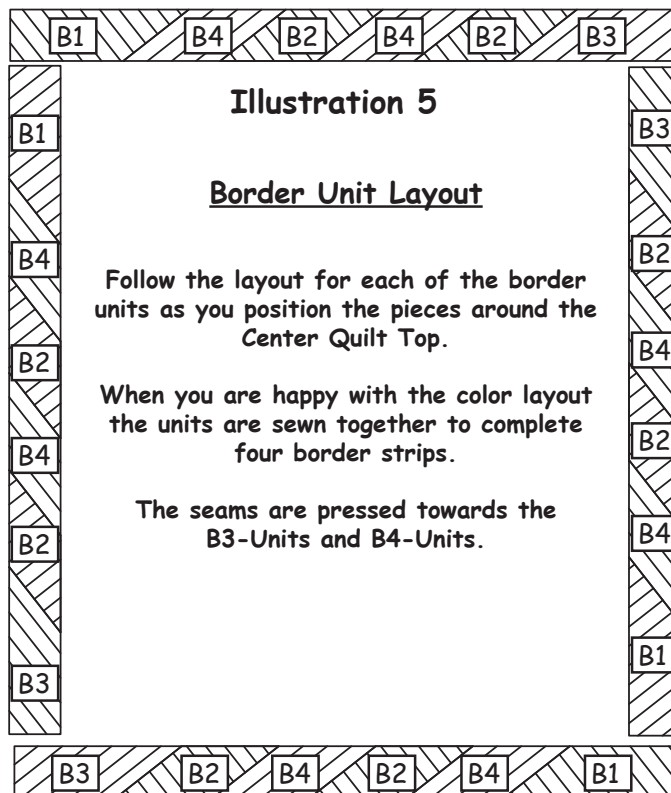

Sewing on the Borders

1. Measure the length of your quilt top down the center.
2. Trim the side border strips to match your quilt. The length of the quilt top should measure about 69-1/2" long. This measurement will vary depending on the accuracy of your seam allowances. *Illustration 6, Page 11.
3. The side border strips are sewn onto the edge of your quilt top. *Illustration 7, Page 11.
4. Press the seams facing in towards the inner accent border.
5. Measure the width of the quilt top across the center.
6. Trim the top and bottom border strips to match the width of your quilt. The width of your quilt top should measure about 67-1/2" wide. Again the measurement will vary depending on the accuracy of your seam allowances. *Illustration , Page 11.
7. The top and bottom border strips are sewn onto your quilt.
8. Press the seams facing in towards the inner accent border.

Binding Information

Double Folded Straight Edge Binding: The binding strips are cut across the salvage grain. The width of the strips are cut 2-1/2" wide. You will need to cut enough strips to go around the **outer edge of your quilt**. The strips are joined together, then pressed in half before sewing them onto the quilt. The joining seams on your strips should be pressed open to prevent the extra bulk when folding the binding over the edge of your quilt. The binding is sewn onto the top-side of the quilt with your machine and hand stitched on the backside.