

## Preparing and Stacking the Fabrics

Before you begin paper piecing position the pieces in Bag #2 as shown. Stack the template pieces facing *right-side-up* in the same order they are sewn onto the foundation paper. Keep the sew-sides aligned at the top as you stack your pieces.

### Stacking the Fabrics Unit-D2

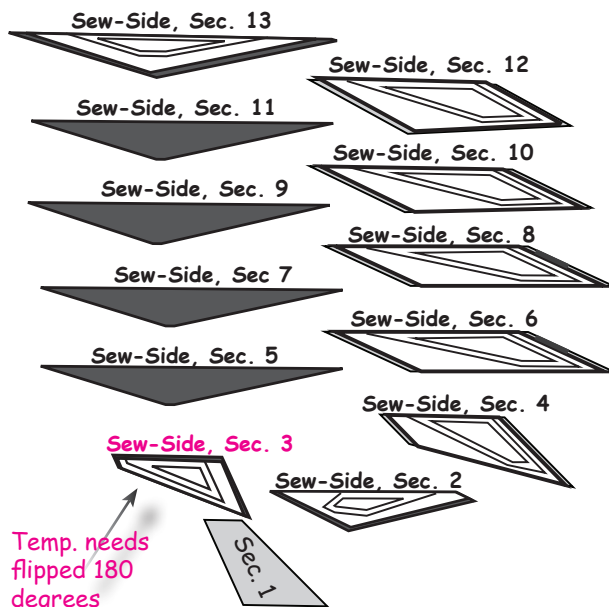

### Template Stacking Order Unit D2:

**Stacking Templates:** Starting with Sec. 13, on the bottom of your stack, continue to stack the pieces in descending order, finishing with Sec. 1 on the top.

*Sec. 13, Spike Template D2-5: right-side-up*

*Sec. 12, Background Template D2-9: right-side-up*

*Sec. 11, Spike Template D2-5: right-side-up*

*Sec. 10, Background Template D2-8: right-side-up*

*Sec. 9, Spike Template D2-5: right-side-up*

*Sec. 8, Background Template D2-7: right-side-up*

*Sec. 7, Spike Template D2-5: right-side-up*

*Sec. 6, Background Template D2-6: right-side-up*

*Sec 5, Spike Template D2-5: right-side-up*

*Sec. 4, Background Template D2-4: right-side-up*

*Sec. 3, Spike Template D2-1: right-side-up*

*Sec. 2 Spike Template D2-3: right-side-up*

*Sec. 1, Background Template D2-2: wrong-side-up*

Remember align the sew-sides at the top as shown below.

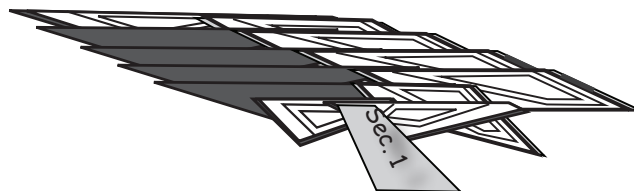

**Step 15:** Place the Add-A-Quarter ruler next to the folded back section on the paper, lip-side down, and trim the fabric with your rotary cutter.

Step 15

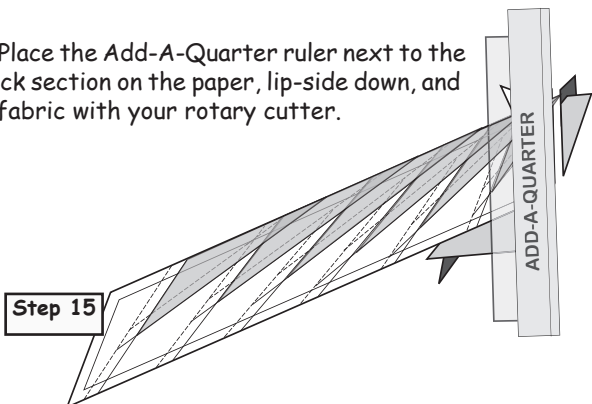

**Step 16:** Place the next piece of fabric for Sec. 3, *right-side-up* next to the folded edge.

Step 16

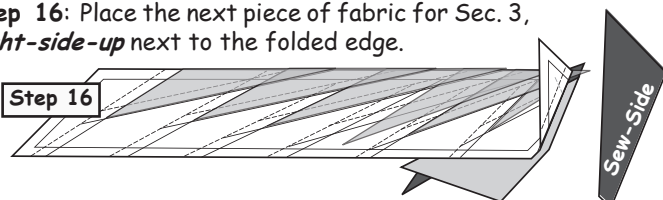

**Step 17:** Lift the foundation paper and position the fabric directly under Sec. 3. Line up the edge of the third fabric with the trimmed quarter-inch seam.

Step 17

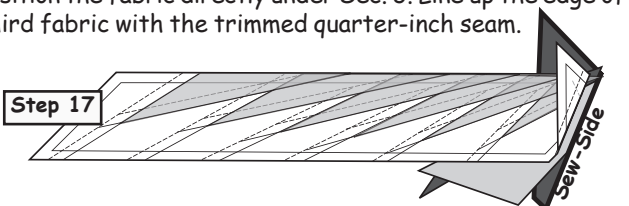

**Step 18:** Open the paper and sew on Line 2. Press the fabric open on the *backside* of the paper.

Press Open

Backside

Step 18

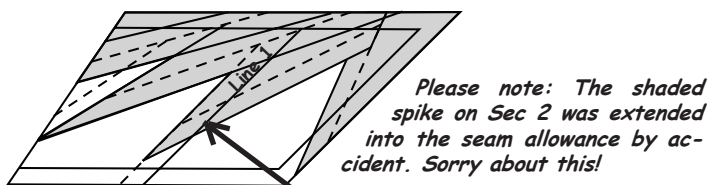
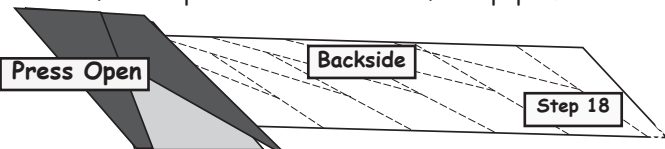

When trimming your quarter-inch seam allowance. Make sure you fold back the paper on Line 3, and not along the edge of the shaded point

**Finishing the Units:** Continue adding the pieces to the foundation papers. When the foundation piecing is finished, trim each piece on the solid line around the outer edge of each unit.

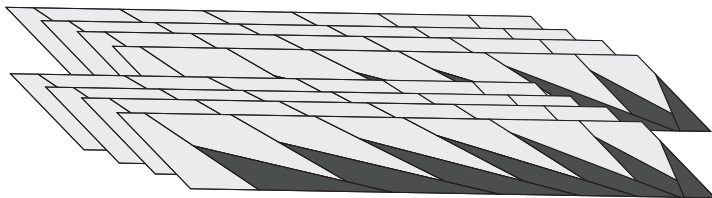

**Note:** Do not remove the foundation paper at this time. The finished sewing lines on the foundation papers are needed to help you located all intersecting points when sewing the pieces onto the stars. The paper will add stability to the bias edges on the lone star diamond pieces. Leaving the paper in place will keep your pieces from stretching.